

SECTION 29 05 00

COMMON WORK INSTRUMENTATION

PART 1 GENERAL

1.1 REQUIREMENTS OF WORK

- A. Install and assist in commissioning a complete instrumentation and control (I&C) system as shown on the Drawings and as specified herein.
- B. Programming and configuration of the control system will be by others.
- C. Supply of the field instruments will be by others.
- D. Component subsystems of the I&C system will include, but are not limited to, the following:
 - 1. Primary elements and transmitters
 - 2. Final control elements
 - 3. I&C field devices
 - 4. I&C junction boxes and marshalling panels
 - 5. Instrumentation cabling
 - 6. Instrumentation power supplies
 - 7. Conduit and cable tray
- E. The Contractor's responsibility also includes receiving, uncrating, examining for shortages or damage, assembling, field fitting, installing, mounting, wiring and testing of City supplied component subsystems.
- F. Where packaged, stand-alone control systems are supplied by others provide cabling to connect to the required remote monitoring and/or control functions. Provide end-to-end Commissioning of all required remote monitoring and/or control functions. Assist in ensuring the correct functionality of any equipment supplied by others.
- G. Documentation referred to in 1.1.1 to include as a minimum:
 - 1. Records of as-built information for the complete instrumentation system.
- H. Documentation provided is formatted as follows:
 - 1. Piping & Instrumentation Diagrams (P & IDS) – depict the general intent of the control systems and are to be used as the governing document for the scope of Work.
 - 2. Instrument Index – an index of the detailed information for the devices shown on the P & IDs. The index lists the appropriate support documentation for the devices' supply and installation. The instrument index is the controlling document for the supply of materials.

3. Input/Output (I/O) Index – an index of the control system I/O points shown on the P & IDs, giving the supporting documentation as per the instrument index.
4. Instrument Specification Sheet – detail the relevant data for the supply of devices.
5. Instrument Loop Diagrams (ILDs) – show typical interconnections and hook-up of devices.
6. Location Drawings – indicate in plan and/or elevation views where the instrument elements are physically located. These Drawings are provided to assist the Contractor in estimating the amount of cable and ducting required.
7. Standard Details – provide a reference for installation, operation and other instructions pertinent to a particular device.
8. Detailed Specification – lists qualifications, quality of materials and workmanship, and supplementary information.

I. Definitions

1. Interpret specialized terms not explicitly defined herein in accordance with ISA-S51.1, NEMA-ICS-1, ANSI/IEEE-Std-100, and The Communications Standard Dictionary, by Martin H. Weik.

J. References

1. This Specification contains references to the following Documents. They are a part of this Section as specified and modified. In case of conflict between the requirements of this Section and those of the listed Documents, the requirements of this Section prevail.

Reference	Title
API RP550-86	Manual on Installation of Refinery Instruments and Control Systems, Part I--Process Instrumentation and Control Sections 1 Through 13
ASME Section VII-89	Rules for Construction of Pressure Vessels
ASTM B68-86	Seamless Copper Tube
ASTM D883-89	Terms Relating to Plastics
IEEE 100-88	Dictionary of Electrical and Electronic Terms
ISA RP7.1-56	Pneumatic Control Circuit Pressure Test
ISA RP12.6-87	Installation of Intrinsically Safe Systems for Hazardous (Classified) Locations
ISA S5.4-76	Instrument Loop Diagrams
ISA S18.1-79	Annunciator Sequences and Specifications
ISA S51.1-79	Process Instrumentation Terminology
NEMA 250-85	Enclosures for Industrial Controls and Systems
NEMA ICS 1-88	General Standards for Industrial Control and Systems
NEMA ICS 2-88	Industrial Control Devices, Controllers, and Assemblies
NFPA 70-90	National Electrical Code (NEC)
SAMA PMC 17-10-63	Bushings and Wells for Temperature Sensing Elements
UBC-88	Uniform Building Code
UL 1012-89	Power Supplies
UL 94-80	Tests for Flammability of Plastic Materials for Parts in Devices and Appliances, Weik, Martin H. Communications Standard Dictionary, Van Nostrand Reinhold Co., 1983

K. Related Work:

1. Mechanical
2. Electrical

L. Qualifications

1. The instrumentation Subcontractor shall be a firm normally engaged and fully competent in the type of Work described in this Section of the Specification. The firm shall have been continuously and successfully engaged in this business for at least five years.
2. Qualified journeyman instrument mechanics that are familiar with the devices being installed shall perform all instrument hook-ups, calibrations, and checkouts.
3. Qualified journeyman electricians shall perform all control wiring installation and connections.

M. Codes, Rules, Permits & Fees

1. Comply with all laws, ordinances, rules, regulations, codes and orders of all authorities having jurisdiction relating to this Work.

2. Comply with all rules of the Electrical Safety Act of the Province, CSA Standards, the ULC and the applicable building codes, whether specifically shown on Drawings or not.
 3. Give all required notices, submit Drawings, obtain all permits, licenses and certificates and pay all fees required for this Work.
 4. Furnish a certificate of final inspection and approvals from an inspection authority to the Contract Administrator.
- N. Standards of Workmanship
1. Execute all Work in a manner, which will result in the completed installation presenting an acceptable appearance, to a level of quality defined in the general conditions of this Specification.
 2. Employ a competent supervisor and all necessary licensed tradesmen to complete the Work in the required time.
 3. Arrange and install products to fit properly into designated building spaces.
 4. Install products in accordance with the recommendations and ratings of the product manufacturers.
- O. Contract Drawings and Specifications
1. Refer to Division 1.
 2. Provide all items and accessories required to install City supplied equipment.
 3. Perform all operations as designated by the Specification according to the methods prescribed, complete with all necessary labour and incidentals.
 4. Treat any item or subject omitted from this Division's Specifications or Drawings, but which is mentioned or reasonably specified in other Divisions' Specifications or Drawings and pertains to the instrumentation and control system, as being integral to the overall system. Provide such specified items or subjects.
 5. Provide all minor items and Work not shown or specified but which are reasonably necessary to complete the Work.
 6. If discrepancies or omissions in the Drawings or Specifications are found, or if intent or meaning is not clear, consult the Contract Administrator for clarification before submitting bid.

1.2 EQUIPMENT

- A. Receiving, Storing, and Protection of Components during Construction
Examine each component upon delivery to Site. Report all damage noted to the Contract Administrator prior to accepting or rejecting delivery. All instrumentation primary elements, control components, panels, etc. shall be placed in a secure, dry, heated storage building. Maintain the space temperature above 10°C and the space relative humidity below 50 percent.
- B. Perform a preliminary examination upon delivery to ensure that:
1. All instrumentation and control components supplied for this project under this Section of the Specification comply with the requirements stated in the instrument Specification sheets.

2. All instrumentation and control components supplied by others, to be connected to instrumentation and control components comply with the requirements stated in the Contract Documents.
3. Itemize all non-conformities noted above and forward them to the Contract Administrator.
4. Do not install primary elements or other sensitive equipment until construction is sufficiently completed to provide an "operating condition" environment. Notify the Contract Administrator prior to installing any equipment of this type.
5. Ensure that covers where required are properly installed on all equipment. Provide all covers, padding, guards, etc. as required to guard any equipment against damage.
6. Return all damaged equipment to the supplier for total corrective repairs. If deemed necessary by the Contract Administrator, the damaged equipment shall be replaced with new product.

1.3 SITE

- A. Classification of Plant Areas
 1. Refer to Division 26.

1.4 DOCUMENTATION

- A. Submittals
 1. Submit Shop Drawings for all products supplied by this Division.
 2. Shop Drawings for City supplied equipment will be provided to the Contractor
- B. Construction Record Drawings
 1. Maintain on-site a complete set of Construction Record Drawings as listed in Division 1 of this Specification.
 2. In addition to the requirements as stated in Division 1, record the following information on the Drawings:
 - a. All changes, alterations or additions
 - b. All instrumentation cable and control tubing
 - c. All changes to the numbers and location of outlets, motors, panels and end devices that may occur during the course of the Work.
 3. Before requesting the Certificate of Total Performance, make any necessary final corrections to the Drawings, sign each print as a certification of accuracy and deliver all sets to the Contract Administrator for approval.

PART 2 PRODUCTS

2.1 GENERAL

- A. Refer to the requirements of Division 1.
- B. Selected Products:
 1. Provide products and materials that are new and free from all defects.

2. The design has been based on the use of the first named product where multiple products have been listed.
- C. Quality of Products
1. All products provided to be CSA and ULC approved where applicable.
 2. If products specified are not CSA approved, obtain approval of the relevant provincial regulatory authority. Pay all applicable charges levied and make all modifications required for approval.
 3. Refer to Division 1 of this Specification for further information.
- D. Uniformity of Manufacture
1. Unless otherwise specifically called for in the Specification, uniformity of manufacture to be maintained for similar products throughout the Work.
- E. Use of Products During Construction
1. Any equipment used for temporary or construction purposes is to be approved by the Contract Administrator. Clean and restore to "as new" condition all equipment prior to the time of Substantial Performance.

2.2 INSTRUMENTATION

- A. General
1. Instruments and installation methods to be suitable for the environmental conditions in which they are to be installed.
 2. Determine where injurious conditions may be expected to occur and make proper provision to protect the instruments to ensure their proper and reliable operation.

2.3 IDENTIFICATION

- A. Refer to Division 26 for general identification requirements. Provide lamicoïd nameplates with 6 mm white lettering on black background. Identify the loop tag number (where applicable) and the device name, function, and instrument range or setpoint value on the nameplate.
- B. Where it is not possible to attach a lamicoïd nameplate to a field instrument component, provide the component with a stainless steel metal tag firmly wired to the device and identified with the loop tag number.
- C. Identify all wires where they terminate at the marshalling panels, junction boxes and field devices with a heat shrink sleeve with machine printed labeling.
- D. Clearly mark all panels, pull boxes, junction boxes, etc. to indicate the nature of service.
- E. Provide neatly typed circuit directories for panel power distribution systems to indicate loops or devices powered by the circuit and the fuse size.

- F. Identify all exposed control conduits at all pull box locations, where the conduits enter or leave a room, and 13 m on centre throughout the room. This shall apply to conduits above removable ceilings. Use Thomas & Betts TY-RAP 5532-M labels conduit identification.
- G. For direct current wiring use black for positive and white for negative.
- H. For thermistor wiring to motors use red and blue coloured, insulated wire.

PART 3 EXECUTION

3.1 SITE EXAMINATION

- A. Refer to the requirements of Division 1.
- B. No additional compensation will be given for extra Work due to existing conditions that a Site examination prior to Bid should have disclosed.

3.2 COORDINATION WITH OTHER DIVISIONS

- A. Examine the Drawings and Specifications of all Divisions and become fully familiar the Work. Before commencing Work, obtain a ruling from the Contract Administrator on any conflicting issues between Divisions. No compensation will be made for any costs arising from conflict not identified before Work has commenced.
- B. Coordinate the Work to be performed under this Section of the Specification with all Divisions installing equipment to ensure that there are no conflicts.
- C. Install anchors, bolts, pipe sleeves, hanger inserts, etc. required in ample time to prevent delays to other Division's installation Work.
- D. Lay out the Work and equipment with due regard to architectural, structural and mechanical features. Architectural and structural Drawings take precedence over electrical Drawings regarding locations of walls, doors, and equipment.
- E. Structural members shall not be cut without prior approval of the Contract Administrator.
- F. Examine previously constructed Work and notify the Contract Administrator of any conditions, which prejudice the proper completion of this Work.

3.3 PRODUCT HANDLING

- A. Use all means necessary to protect the products included in this Division before, during and after installation, and to protect products and installed Work of all other trades.
- B. Any damage to the products and/or installed Work shall be repaired or replaced by the Contractor at no additional cost to the City and to the approval of the Contract Administrator.

- C. Remove advertising labels from all products installed that have such labels attached. Identification or CSA labels are not to be removed.
- D. Remove dirt, rubbish, grease, etc. resulting from Work performed under this Division of the Contract from all surfaces.

3.4 SEPARATION OF SERVICES

- A. Maintain separation between the electrical wiring system, piping, ductwork, and the instrumentation cables so that each system is isolated (except at approved connections to such systems) to prevent galvanic corrosion. In particular, contact between dissimilar metals, such as copper and aluminum, in damp or wet locations is unacceptable.
- B. Do not support wiring from pipes, ductwork, etc. Hangers for suspended ceilings are not to be used for the support of wiring.
- C. Classifications of Circuits
 - 1. The circuit categorization shall of first priority follow Canadian Electrical Code with respect to separation for electrical safety and the following shall apply with respect to electro-magnetic compatibility:

Reference	Title
Very Noisy	High voltage circuits and their associated grounding
	High current (>200 A) LV circuits.
	Harmonic-rich LV circuits
	DC circuits: un-suppressed or above 50 V
Noisy	Low current class two (2) circuits
	Medium power pulsed or radio frequency circuits
Indifferent	ELV digital status circuits
	Intrinsically safe circuits
	Telecommunications circuits
	Fire alarm and emergency lighting circuits (note that some fire alarm circuits may fall into the category of signal circuits).
	Any other emergency, shutdown, or high integrity circuit (e.g. toxic gas alarm).
Sensitive	Analogue signal circuits
	Data communication circuits
Very Sensitive	Low level voltage and current signals (e.g. from instrument sensors).

- D. Separation of Circuits
 - 1. This Section relates to the running of cables carrying differing types of circuit in close proximity to one another and to other services. Sensitive circuits shall normally be run in overall shielded cable. Very sensitive circuits shall normally be run in individually twisted pair shielded cable.

2. For cables sharing the same support/containment system, the following shall provide guidance to minimize extraneous interference.

Segregation Between circuits	Very Noisy	Noisy	Indifferent	Sensitive	Very Sensitive
Very Noisy	Thermal grouping as per CE Code	150 mm	300 mm	300 mm	300 mm
Noisy	150 mm	Thermal grouping as per CE Code	150 mm	150 mm	150 mm
Indifferent	300 mm	150 mm	Separation of circuit types.	100 mm	100 mm
Sensitive	300 mm	150 mm	100 mm	Touching	50 mm
Very Sensitive	300 mm	150 mm	100 mm	50 mm	Touching

3.5 WIRE AND CABLE

- A. Refer Division 26.

3.6 EQUIPMENT CONNECTIONS

- A. Prior to the connection of signal wiring to process control and instrumentation devices, check the device voltage rating and polarity for compatibility with the corresponding loop and/or schematic diagram. Where device and circuit characteristics are found to be incompatible, the connections are not to be made. Report the condition immediately to the Contract Administrator.
- B. All control wiring diagrams illustrate typical control circuits applicable to the type of equipment specified. Control circuits may vary with different manufacturer's equipment. Verify all control circuits with the manufacturers of the equipment and make any corrections to the control wiring diagrams that may be required.

3.7 WIRING TO EQUIPMENT SUPPLIED BY OTHER DIVISIONS

- A. Equipment supplied by the City or by other Divisions, that have external or field mounted control devices, are to be installed, wired and commissioned by this Division.

3.8 INSTRUMENT MOUNTING STANDS

- A. Supply and install instrumentation mounting stands as required. Stands are to be either floor or wall mounted. The mounting stands are to be fabricated from aluminum.
- B. Supply and install protective drip shields for any exterior stand-mounted instrumentation equipment. Drip shields are to extend 50 mm past the front and side faces of the equipment. Drip shields are to be fabricated from aluminum.

3.9 SEALING OF WALL AND FLOOR OPENINGS

- A. Seal all conduit and cable entries passing through walls of buildings, through partition walls separating electrical rooms from other areas, through fire separations, and through floors above grade.
- B. Seal openings after all wiring entries have been completed.
- C. Sealing material shall be fire resistant and shall not contain any compounds that could chemically affect the wiring jacket or insulating material. Cable penetrations through fire separations, if required, are to be sealed. Submit shop drawing for rated assembly prior to installation of fire stop.

3.10 TAGGING STANDARDS FOR DEVICES AND WIRING

- A. Tag all devices, wires, and I/O using the assigned loop, equipment, or device tag name. Where tag naming and numbering is not specified, the Contract Administrator will provide naming and numbering that is consistent with the plant naming conventions.

3.11 TESTING OF INSTRUMENTATION LOOPS

- A. After all devices within a loop have been connected, check the loop for correct functioning and interaction with other loops, where applicable. Provide written notice to the Contract Administrator when the loops are going to be tested so that the tests may be witnessed at the Contract Administrator's discretion.
- B. Check the operation of final control elements such as solenoid valves, actuators, etc. by manual control before checking with automatic control.
- C. Check and simulate all alarms and shutdown functions.
- D. Test all tubing for leaks in compliance with ISA RP7.1. Isolate all instruments when tubing is being tested to protect against over pressure.
- E. Perform tests and record results on the test data forms that are included in this Section. Develop additional and/or more detailed test forms as necessary to suit more complex instrumentation.
- F. Sign and date all test reports. Submit the test reports to the Contract Administrator within five Business Days of testing.
- G. Coordinate and cooperate with City's staff while they verify the instrument loop I/O in the programmable logic controller (PLC) and on the supervisory control and data acquisition (SCADA) system.

3.12 CALIBRATION

- A. Instruments are to be factory pre-calibrated. Verify calibration after installation for all instruments installed under these Specifications. Provide a printed record of the factory calibration parameters for "smart" devices.
- B. Prior to calibration, completely program all "smart" transmitters including entries of the appropriate range and tag number. Provide a printed record of smart device serial numbers against their assigned tag number with all programmed parameters.
- C. Calibrate all instruments to an accuracy of 0.5 percent of full range, or to the manufacturer's stated accuracy of the instrument whenever an accuracy of 0.5 percent is not achievable.
- D. Prior to instrument installation perform the following applicable calibration for each instrument and its associated signal conditioning equipment:
 - 1. Calibrate online analyzers with known samples.

3.13 COMMISSIONING

- A. Refer to the requirements of Division 1 for additional requirements.
- B. Inspections
 - 1. Provide two weeks' written notice to the Contract Administrator prior to energizing any system to allow for inspection by the Contract Administrator of the following:
 - a. Proper mounting
 - b. Proper connections
 - 2. During Commissioning, demonstrate to the Contract Administrator proper calibration and correct operation of instruments and gauges
 - 3. Commissioning of the instrumentation and control system to include but not be limited to the following:
 - a. Verify installation of components, wiring connections and piping connections.
 - b. Supervise wiring continuity and pipe leak tests.
 - c. Verify instrument calibration and provide written report.
 - d. Function check and adjust the instruments and control equipment under operational conditions.
 - e. Coordinate manufacturer's service personnel as required for complete system testing.
 - f. Instruct plant personnel in correct method of instruments equipment operation.
 - g. Direct plant personnel at hand-over as to final adjustment of the system for correct plant operation.
 - h. Ensure that the Manufacturer's representatives cooperate to complete the Work of this Section.
 - i. Verify signal levels and wiring connections to all instrumentation and control equipment.

- j. Work with control system programmer to verify all field devices, wiring, calibration and operation

3.14 SUPPLEMENTS

- A. Form No. 1, ITR – Instrument Test Report
- B. Form No. 2, LCR – Loop Check Report

END OF SECTION

INSTRUMENT TEST REPORT

SYSTEM: _____

SERVICE: _____ TAG NO. _____

LOCATION: _____

MAKE: _____ MODEL: _____

SERIAL NO.: _____ CSA: _____

ELEMENT: _____ RANGE: _____

DESIGN SETTING/RANGE: _____ CONTACT TO: _____ ON: _____

SIGNAL IN: _____ OUT: _____ ASSOCIATED INSTRUMENT: _____

INSTRUMENT CONDITION: _____ CONFORM TO SPEC: _____

PROJECT NO.: _____ DATA SHEET: _____

	TEST 1				TEST 2			
	TEST METHOD							
	INPUT		OUTPUT		INPUT		OUTPUT	
PROCESS	INC.	DEC.	INC.	DEC.	INC.	DEC.	INC.	DEC.
TEST POINT 1								
TEST POINT 2								
TEST POINT 3								
TEST POINT 4								
TEST POINT 5								
COMMENTS								
GRAPHS								

TESTED BY: _____ CHECKED BY: _____

DATE: _____ DATE: _____

LOOP CHECK REPORT

- CHECKED OUT OK
- NOT APPLICABLE
- FURTHER ACTION REQUIRED

	INSTRUMENT TAG NO.								
LOOP NO. _____									
SHEET NO. _____									
P & I DWG. NO. _____									
INSTALLATION COMPLETE									
Primary Element									
Impulse Lines									
Block and Drain Valves									
Air Supply/Filter/Reg.									
Wiring									
Tracing/Insulation/Housing									
Mounting and Location									
PLC/SCADA I/O & Status									
CALIBRATED									
Impulse Lines Press. Tested									
LOOP CHECKED									
Element To Receiver									
X Mtr. to Receiver									
X Mtr./Trans. to Receiver									
X Mtr./Trans. to Switches									
Switches to Annunciator									
Interlocking Circuit									
Controller to Valve									
Controller Action D or R									

REMARKS:

READY FOR START-UP

DATE: _____

Installed by: _____

Checked by: _____

SECTION 29 10 01

ENCLOSURES

PART 1 GENERAL

1.1 REFERENCES - GENERAL

- A. Suppliers, Equipment, Products, and Execution must meet all requirements detailed in Section 29 05 00, Common Work Instrumentation.
- B. Local control stations shall be supplied to house local control switches, push buttons and indicator lights associated with field devices (valves, drives etc). The control stations shall be located in close proximity to their associated devices. Where a group of devices are located within close proximity to each other, the local controls may be combined into a single common local control panel. Line of site must be maintained between all devices and the respective local controls.

PART 2 PRODUCTS

2.1 GENERAL

- A. Unless otherwise specified, provide outside finishes on all enclosures in ANSI 61 Grey.
- B. The enclosures must be suitable for carrying the weight of the equipment mounted inside the panel and on the doors without any warpage.

2.2 ENCLOSURES

- A. Provide Electrical EEMAC Type 4x enclosures for Category 1 and 2 locations.

2.3 WIRING AND ACCESSORIES

- A. Provide wiring inside the enclosures according to the following Specifications:
 - 1. Control wiring to be a minimum of #16 AWG tinned stranded copper; insulation rated at 600 V.
 - 2. Wiring for power distribution shall be a minimum of #14 AWG tinned stranded copper; insulation rated at 600 V.
 - 3. Install cables in accordance with the requirements of Division 26.
- B. Tag each wire at both ends with a heat shrink sleeve that is machine printed. Allow approximately 20 mm of wire insulation between the tag and the bare wire.
- C. Wiring systems with different voltage levels or types shall be suitably segregated within the panel, according to relevant electrical codes.

- D. Run all wiring in enclosed plastic wireways such as Panduit. Size all wireways so that the total cross sectional area of the insulated wire and cable does not exceed 40 percent of the cross sectional area of the wire way.
- E. Provide a minimum clearance of 50 mm between wire ways and any point of wire termination.
- F. Terminate all wiring, incoming and outgoing, at terminal strips mounted inside the enclosure. Identify each terminal strip with a terminal strip number, defined as follows:
 - 1. Wire identification to use the connected field device tag name with the wire's corresponding end device terminal number appended to it.
 - 2. Identify every joint and/or terminal of the above wire run with the same identifier until the wire meets another tagged device, at which point the wire identifier will change to use the new device name and terminal number.
 - 3. For example, pressure transmitter FIT-740 located in the field has a 1 PR-TPSH cable connected to it. The cable runs through a junction box to a marshaling panel. The wire identifiers for the pair of wires would be FIT-740 all the way to the marshaling panel.
 - 4. Identify spare wires by using the cable tag, wire number and an “-SP” suffix.
 - 5. Arrange wiring on terminal blocks such that all internal panel wiring terminates on the inboard side of the terminal blocks and all external wiring terminates on the outboard side.
- G. Provide sufficient terminals so that not more than two wires are connected under the same terminal. Provide 20 percent spare terminal capacity at each terminal block assembly.
- H. Terminals shall be Weidmuller W Series color coded as follows:
 - 1. Red = positive 24 VDC
 - 2. Black = analog signal plus
 - 3. White = analog signal common and VAC neutral
 - 4. Grey = 120 VAC
 - 5. Green = ground
- I. Provide nameplates for each device on or within the panels and enclosures. Nameplates shall be white lamicoïd with black lettering, a minimum of 25 mm x 75 mm in size with up to three lines of 5 mm lettering. Securely fasten nameplates in and situate them in a visible location.

2.4 PANEL GROUNDING

- A. Provide a ground system for the instrumentation circuits.
- B. Provide grounding lugs for each panel, suitable for termination of up to #2 AWG copper grounding conductor.
- C. Firmly bond all panel-mounted devices on or within the panels to ground. Provide supplementary bonding conductors for backpanels and doors. Attach a separate bonding

conductor to all devices that are not firmly fastened to the panels with screws for such devices as case mounted instruments, meters, etc.

PART 3 EXECUTION

3.1 MOUNTING HEIGHTS

- A. Unless otherwise specified or a conflict exists, mount all panels, starters and disconnects 2000 mm to top of cover.

END OF SECTION

SECTION 29 15 01

INSTRUMENTATION CABLE

PART 1 GENERAL

1.1 REFERENCES

- A. Canadian Standards Association (CSA International)
 - 1. CSA-C22.2 No. 214, Communications Cables (Bi-National standard with UL 444).
 - 2. CSA-C22.2 No. 232, Optical Fiber Cables.
- B. Telecommunications Industry Association (TIA)/Electronic Industries Alliance (EIA)
 - 1. TIA/EIA-568-B.1, Commercial Building Telecommunications Cabling Standard, Part 1: General Requirements.
 - 2. TIA/EIA-568-B.2, Commercial Building Telecommunications Cabling Standard, Part 2: Balanced Twisted-Pair Cabling Components.
 - 3. TIA/EIA-568-B.3, Optical Fiber Cabling Components Standard.
 - 4. TIA/EIA-606-A, Administration Standard for the Commercial Telecommunications Infrastructure.
 - 5. TIA TSB-140, Telecommunications Systems Bulletin - Additional Guidelines for Field-Testing Length, Loss and Polarity of Optical Fiber Cabling Systems.
 - 6. TIA-598-C, Optical Fiber Cable Color Coding.

1.2 DEFINITIONS

- A. Refer to TIA/EIA-598-C, Annex A for definitions of terms: optical-fiber interconnect, distribution, and breakout cables.

1.3 PRODUCT DATA

- A. Submit product data in accordance with Division 26.

1.4 RELATED WORK

- A. Refer to Division 26.

1.5 INSPECTION

- A. Provide adequate notice to the Contract Administrator so that all cable installations can be inspected prior to energizing equipment.

1.6 STANDARDS

- A. All wire and cable shall be CSA approved.

PART 2 PRODUCTS

2.1 TWISTED PAIR SHIELDED CABLES (TPSH)

- A. TPSH shall be constructed as follows:
1. Two (2) copper conductors, stranded, minimum #18 AWG, PVC insulated, twisted in nominal intervals of 50 mm
 2. Insulated for 600 V, 90°C
 3. 100 percent coverage aluminum foil or tape shield
 4. Separate bare stranded copper drain wire, minimum #18 AWG
 5. Overall flame retardant PVC jacket to CSA-C22.2
 6. The entire cable assembly to be suitable for pulling in conduit or laying in cable tray.
 7. Interlocked aluminum armour and outer PVC jacket.
 8. Shaw Type 1751-CSA
- B. Where multi-conductor TPSH cables are called for, each pair shall be individually shielded, continuous number coded, and the cable assembly shall have an overall shield and overall flame retardant PVC jacket.

2.2 RTD AND MULTI CONDUCTOR SHIELDED CABLE

- A. RTD cables shall be CSA approved and shall be constructed as follows:
1. Three or more copper conductors, stranded, minimum # 18 AWG
 2. PVC insulated for 600 V
 3. 100 percent coverage aluminum foil or tape shield
 4. Separate bare stranded copper drain wire
 5. Interlocked aluminum armour and outer PVC jacket.
 6. Overall flame retardant PVC jacket to CSA-C22.2

2.3 TECK CABLES

- A. As per Division 26.

2.4 WIRE

- A. As per Division 26.

2.5 100 BASE TX CATEGORY 5E COMMUNICATION CABLE

- A. Category 5E cable shall be CSA approved and constructed as follows:
1. 4 bonded pairs, solid stranded, #24 AWG
 2. Interlocked aluminum armour
 3. Rip cord
 4. PVC inner and outer jackets
 5. UL verified to Category 5E
 6. Insulated for 300 V
 7. Belden 121700A

2.6 OPTICAL-FIBER CABLE

- A. Distribution without conductive members, multi-mode 50/125, laser-optimized, 2000 MHz km capacity, 12 strands to: CSA-C22.2 No. 232 and TIA/EIA-568- B.3, flame test classification FT4, each end terminated with duplex SC connectors.
- B. Interlocked aluminum armour.
- C. PVC inner and outer jackets.

2.7 OPTICAL-FIBER PATCH PANEL

- A. Mounted in rack 48cm wide, 1rack units, with cover, capable of terminating 6 pairs of fiber, equipped with duplex SC compatible adapters.

2.8 OPTICAL-FIBER PATCH CORDS

- A. Interconnect cable, 2 strands, 1 metres long, each end equipped with duplex SC connectors. Multi-Mode 50/125, laser-optimized, 2000 MHz km capacity to: TIA/EIA-568-B.3.

PART 3 EXECUTION

3.1 ANALOG SIGNALS

- A. Use TPSH cable for all low level analog signals such as 4-20 mA, pulse type circuits 24 VDC and under, and other signals of a similar nature.
- B. Use RTD cable for connections between RTDs and transmitters or control system RTD inputs.

3.2 DIGITAL SIGNALS

- A. Use TPSH cable for all low level input (24 V and below) and output signals to the control system.

3.3 INSTRUMENT POWER

- A. Use Teck cable or wire and conduit for power to instruments, for 120 V signals other than those mentioned above and as otherwise indicated on the Drawings. Use stranded wire and cable to supply power to instruments.

3.4 INSTALLATION

- A. Install instrumentation cables in cable trays. Use a minimum of 300 mm and a maximum of 1000 mm length of liquid tight flexible conduit to connect the field sensors to the conduit.

- B. Where instrumentation cables are installed in cable trays, provide barriers in the tray to separate instrumentation cables from power cables.
- C. At each end of the run leave sufficient cable length for termination.
- D. Do not make splices in any of the instrumentation cable runs.
- E. Cable shields shall be terminated on insulated terminals and carried through to the extent of the cable.
- F. Ground cable shields at one end only. Unless otherwise specified, ground the shields at the PLC control panel.
- G. Protect all conductors against moisture during and after installation.

3.5 CAT 5E INSTALLATION:

- A. Always follow the Manufacturer's guidelines for minimum bend radius and tension.
- B. All installations and terminations shall be performed by personnel experienced in Cat 5E cable installation.
- C. Perform cable testing with time domain reflectometer instrument and provide complete detailed test report. Test all runs upon completion of permanent terminations, using instrumentation acceptable to Contract Administrator. Before commencing testing, submit sample test data sheets and information with respect to test instrumentation to be used.
 - 1. Test for the following:
 - a. Continuity.
 - b. Pair placement and polarity.
 - c. DC resistance.
 - d. Characteristics at highest contemplated frequency:
 - 1) Attenuation - data cable.
 - 2) Mutual Capacitance - data cable.
 - 3) Near-end crosstalk (NEXT) - data cable.
 - e. Run length.
 - 2. Category 5e using certified level IIe tester to: TIA/EIA-568-B.1.
 - 3. Reconnect or re-install and retest as necessary to correct excessive variations.

3.6 INSTALLATION OF FIBRE OPTIC CABLES

- A. Install backbone cables from each communications panel as indicated and according to manufacturers' instructions.
 - 1. Identify and label as indicated to: TIA/EIA-606-A.
- B. FIELD QUALITY CONTROL
 - 1. Test horizontal UTP cables as specified below and correct deficiencies provide record of results as hard copy.
 - a. Perform tests for Permanent Link on installed cables, including spares:

- 1) Category 5e using certified level Iie tester to: TIA/EIA-568-B.1.
 - b. Perform tests for Channel on 100% of cross-connected data horizontal cabling installed from each telecommunications room, including shortest and longest drops from each telecommunications room.
 - 1) Category 5e using certified level Iie tester to: TIA/EIA-568-B.
2. Test Optical-fiber strands for attenuation to: TIA/EIA-568-B.1 and correct deficiencies: provide record of results as hard copy.
 - a. Test horizontal links need at only one wavelength (850 nm or 1300 nm) and in one direction.
 - 1) Attenuation to be less than 2.0 dB, unless consolidation point is used.
 - 2) If consolidation point is used, attenuation test result to be less than 2.75 dB when testing between horizontal cross-connect and telecommunications outlet/connector.
 - b. Test backbone links in both direction. Backbone links:
 - 1) Test multi-mode fiber at both applicable wavelengths (850 nm and 1300 nm).
 - c. Maximum attenuation: Cable attenuation + Connector loss + Splice loss.
 - 1) Multi-mode-fiber attenuation coefficients:
 - a) 3.5 db/km @ 850 nm; and
 - b) 1.5 db km @ 1300 nm
 - 2) Maximum connector insertion loss: 0.75 db per pair and maximum splice insertion loss: 0.3 db.
- C. Perform additional Tier 2 tests using optical time domain reflectometer (OTDR) on backbone fiber pairs to: TSB-140.
 1. Correct deficiencies.
 2. Provide record of results as described in SUBMITTALS.
- D. Provide record of results as hard copy to: TIA/TSB-140.

3.7 CONDUCTOR TERMINATIONS

- A. All equipment supplied shall be equipped with terminal blocks to accept conductor connections.
- B. Instrumentation conductors, where terminated at equipment terminals other than clamping type terminal blocks, shall be equipped with Burndy-YAE-2 or STA-KON, self-insulated, locking type terminators, sized as required to fit conductors and screw terminals.

3.8 TESTING

- A. Test all conductors for opens, shorts, or grounds. Resistance values shall not be less than those recommended by the cable manufacturer.

3.9 IDENTIFICATION

- A. Identify all instrumentation cables.

- B. Identify each conductor with wire numbers using a machine printed Raychem TMS heat shrink wire marker in accordance with B6.

END OF SECTION

SECTION 29 25 01

TRANSMITTERS AND INDICATORS

PART 1 GENERAL

1.1 REFERENCES - GENERAL

- A. Equipment, products and execution must meet all requirements detailed in Section 29 05 00, Common Work Instrumentation.

PART 2 PRODUCTS

2.1 GENERAL TRANSMITTERS AND INDICATORS

- A. Transmitters and indicators will be supplied by others.
- B. All transmitters will have local indication scaled in engineering units as specified in the engineering Specifications. Provide a lamicaid label indicating the calibrated range and engineering units and mount adjacent to the transmitter. Mount the transmitter so the indicator is visible by operations personnel.

PART 3 EXECUTION

3.1 COORDINATION REFERENCES - GENERAL

- A. Refer to Section 29 05 00, Common Work Instrumentation.

END OF SECTION

SECTION 29 30 01

SWITCHES AND RELAYS

PART 1 GENERAL

1.1 REFERENCES - GENERAL

- A. Refer to Section 29 05 00, Common Work Instrumentation.

PART 2 PRODUCTS

2.1 GENERAL

- A. Use normally closed contacts for alarm actuation. The contacts open to initiate the alarm.
- B. Use normally open contacts to control equipment. The contacts close to start the equipment.
- C. Contacts monitored by solid state equipment to be hermetically sealed and adequately rated for the connected load.
- D. Contacts monitored by electro-magnetic devices such as mechanical relays to be rated NEMA ICS 2, designation B300.
- E. Provide double barriers between switch elements and process fluids such that failure of one barrier will not permit process fluids into electrical enclosures.
- F. Switch electrical enclosures to be rated EEMAC 4, minimum.
- G. 120 VAC switches to have a 4 A rating.

2.2 INDICATORS, PUSHBUTTONS AND SELECTOR SWITCHES

- A. All control indicator lamps, pushbutton switches, and selector switches to be Allen Bradley 800H series.
- B. All control indicator lamps shall be push-to-test type.

2.3 RELAYS

- A. The Quality and type of relays shall be based on Omron relays.
- B. 120 VAC relays to be Model LY 4PDT, plug-in, complete with test button and operation indicator, and surge suppressor.

- C. 24 VDC relays to be Model MY 2PDT plug-in, complete with test button and operation indicator, and surge suppressor diode.
- D. Time delay relays for behind panel mounting to be Model H3BA, 2PDT, plug-in, and programmable for sixteen (16) time ranges and four (4) operation modes.
- E. Time delay relays for flush panel mounting and operator accessible timing range modifications to be Model H5BR, SPDT, screw terminals, programmable for five (5) timing ranges and eight (8) operation modes, complete with digital display, module for time settings and flexible protective cover.
- F. Where the contact ratings of the relays listed are insufficient for the application select an appropriate type from an approved Manufacturer with the same quantity of contacts as was originally specified.
- G. Provide relay plug-in sockets for DIN mounting complete with stacked screw clamp terminals.

2.4 POTENTIOMETER

- A. Potentiometer for field adjustment of variable speed pumps.
- B. Potentiometer complete with 1-100% scale.
- C. Rating: 10k Ω , ½ Watt
- D. Complete with analog signal convertor capable of converting signal to 4-20 mA.
- E. Potentiometer and signal convert to be housed in single enclosure.

PART 3 EXECUTION

3.1 REFERENCES - GENERAL

- A. Refer to Section 29 05 00 - Common Work Instrumentation.

END OF SECTION

SECTION 29 40 11

PLC I-O INDEX

PART 1 GENERAL

1.1 REFERENCES - GENERAL

- A. Refer to Section 29 05 00, Common Work Instrumentation.

1.2 PLC I/O INDEX

- A. The supplements listed below, following “End of Section” are part of this Specification.
 - 1. The following spreadsheet gives an itemized list of the new Programmable Logic Control (PLC) System inputs and outputs. It is intended to serve as an aid for determining the cabling requirements for the Work specified in this Division.

PART 2 PRODUCTS (Not Used)

PART 3 EXECUTION (Not Used)

END OF SECTION

PLC I-O INDEX

RECORD NO.	REV. NO.	TAG NAME	DESCRIPTION		P&ID DRAWING	I/O SPECIFICATION											
			FUNCTION	SERVICE		ENG. UNITS	SCALE		ALARMS		PLC CABINET	I/O TYPE	I/O RACK	I/O CARD	I/O POINT	I/O ADDRESS	
0001	0	P-X101.CmdRun	Start/Stop	Raw Water Pump P-X101	WX-P0001							MCC CP	DO	2.1	3	1	%M33
0002	0	P-X101.Flt	Fault	Raw Water Pump P-X101	WX-P0001							MCC CP	DI	2.1	4	1	%I33
0003	0	P-X101.Run	Running	Raw Water Pump P-X101	WX-P0001							MCC CP	DI	2.1	4	2	%I34
0004	0	P-X101.Auto	H-O-A In Auto	Raw Water Pump P-X101	WX-P0001							MCC CP	DI	2.1	4	3	%I35
0005	0	P-X101.CmdSpeed	Speed Setpoint	Raw Water Pump P-X101	WX-P0001	Hz	0	60				MCC CP	AO	2.1	7	1	%MW9
0006	1	P-X101.Speed	Speed Feedback	Raw Water Pump P-X101	WX-P0001	Hz	0	60				MCC CP	AI	2.1	6	1	%IW64
0006A	1	P-X101.CmdSpeedA	Local Speed Setpoint	Raw Water Pump P-X101	WX-P0001	%	0	100				PLC CP	AI	1.1	14	5	%IW50
0007	1	FV-X101.CmdZ	Position Setpoint	Raw Water Control Valve FV-X101	WX-P0001	%	0	100				PLC CP	AO	1.2	2	1	%MW1
0008	1	FV-X101.Z	Position Feedback	Raw Water Control Valve FV-X101	WX-P0001	%	0	100				PLC CP	AI	1.1	15	1	%IW55
0009	0	FIC-X1020	Flow Indication	Raw Water	WX-P0001	l/sec	0	100				PLC CP	AI	1.1	9	2	%IW2
0010	2	FQ-X1020	Flow Totalization	Raw Water	WX-P0001	m^3						PLC CP	DI	1.1	7	1	%I1
0011	0	AI-X1022.pH	pH Indicator	Raw Water Post Chemical Addition	WX-P0001	pH	0	14				PLC CP	AI	1.1	9	3	%IW3
0012	0	LS-X6010	Level Switch	Building Flood Alarm	WX-P0001							PLC CP	DI	1.1	7	2	%I2
0013	0	LI-X2100	Level Indication	DAF Tank	WX-P0002	mm	0	3000				PLC CP	AI	1.1	9	4	%IW4
0014	0	P-X201.CmdRun	Start/Stop	DAF Recycle Pump	WX-P0002							MCC CP	DO	2.1	3	2	%M34
0015	0	P-X201.Flt	Fault	DAF Recycle Pump	WX-P0002							MCC CP	DI	2.1	4	5	%I36
0016	0	P-X201.Run	Running	DAF Recycle Pump	WX-P0002							MCC CP	DI	2.1	4	6	%I37
0017	0	P-X201.Auto	H-O-A In Auto	DAF Recycle Pump	WX-P0002							MCC CP	DI	2.1	4	7	%I38
0018	0	FI-X2012	Flow Indication	DAF Recycle	WX-P0002	l/sec	0	20				PLC CP	AI	1.1	9	5	%IW5
0019	0	FQ-X2012	Flow Totalization	DAF Recycle	WX-P0002	m^3						PLC CP	DI	1.1	7	3	%I3
0020	0	AI-X3100.Turb	Turbidity Indication	DAF Effluent	WX-P0002	NTU	0	5				PLC CP	AI	1.1	9	6	%IW6
0021	0	SOL-X202.CmdOpn	Solenoid Valve Open	DAF Recycle C/A Supply	WX-P0002							PLC CP	DO	1.1	5	1	%M1
0022	0	LI-X2110	Level Indication	DAF Effluent Overflow Tank	WX-P0002	mm	0	3000				PLC CP	AI	1.1	9	7	%IW7
0023	0	P-X301.CmdRun	Start/Stop	Ozone Contactor TK-X301 Supply Pump	WX-P0002							MCC CP	DO	2.1	3	3	%M35
0024	0	P-X301.Flt	Fault	Ozone Contactor TK-X301 Supply Pump	WX-P0002							MCC CP	DI	2.1	4	7	%I39
0025	0	P-X301.Run	Running	Ozone Contactor TK-X301 Supply Pump	WX-P0002							MCC CP	DI	2.1	4	8	%I40
0026	0	P-X301.Auto	H-O-A In Auto	Ozone Contactor TK-X301 Supply Pump	WX-P0002							MCC CP	DI	2.1	4	9	%I41
0027	0	P-X301.CmdSpeed	Speed Setpoint	Ozone Contactor TK-X301 Supply Pump	WX-P0002	Hz	0	60				MCC CP	AO	2.1	7	2	%MW10
0028	1	P-X301.Speed	Speed Feedback	Ozone Contactor TK-X301 Supply Pump	WX-P0002	Hz	0	60				MCC CP	AI	2.1	6	2	%IW65
0029A	1	P-X301.CmdSpeedA	Local Speed Setpoint	Ozone Contactor TK-X301 Supply Pump	WX-P0002	%	0	100				PLC CP	AI	1.1	14	6	%IW51
0029	1	P-X302.CmdRun	Start/Stop	Ozone Contactor TK-X302 Supply Pump	WX-P0002							MCC CP	DO	2.1	3	4	%M36
0030	0	P-X302.Flt	Fault	Ozone Contactor TK-X302 Supply Pump	WX-P0002							MCC CP	DI	2.1	4	10	%IW42
0031	0	P-X302.Run	Running	Ozone Contactor TK-X302 Supply Pump	WX-P0002							MCC CP	DI	2.1	4	11	%I43
0032	0	P-X302.Auto	H-O-A In Auto	Ozone Contactor TK-X302 Supply Pump	WX-P0002							MCC CP	DI	2.1	4	12	%I44
0033	0	P-X302.CmdSpeed	Speed Setpoint	Ozone Contactor TK-X302 Supply Pump	WX-P0002	Hz	0	60				MCC CP	AO	2.1	7	3	%MW11
0034	1	P-X302.Speed	Speed Feedback	Ozone Contactor TK-X302 Supply Pump	WX-P0002	Hz	0	60				MCC CP	AI	2.1	6	3	%IW66
0034A	1	P-X302.CmdSpeedA	Local Speed Setpoint	Ozone Contactor TK-X302 Supply Pump	WX-P0002	%	0	100				PLC CP	AI	1.1	14	7	%IW52
0035	1	AI-X3150.PH	pH Indicator	Ozone Contactor TK-X301 Supply Pump Discharge	WX-P0002	pH	0	14				PLC CP	AI	1.1	15	2	%IW56

PLC I-O INDEX

RECORD NO.	REV. NO.	TAG NAME	DESCRIPTION		I/O SPECIFICATION												
					P&ID DRAWING	ENG. UNITS	SCALE		ALARMS		PLC CABINET	I/O TYPE	I/O RACK	I/O CARD	I/O POINT	I/O ADDRESS	
0036	1	AI-X3160.PH	pH Indicator	Ozone Contactor TK-X302 Supply Pump Discharge	WX-P0002	pH	0	14				PLC CP	AI	1.1	15	3	%IW57
0037	0	LI-X3200	Level Indication	Ozonated Water Holding Tank	WX-P0003	mm	0	3000				PLC CP	AI	1.1	9	8	%IW8
0038	0	AI-X3202.DO3	Dissolved Ozone	Ozone Contactor Effluent	WX-P0003	ppm	0	2				PLC CP	AI	1.1	10	1	%IW10
0039	0	P-X401.CmdRun	Start/Stop	Filter Columns FIL-X411 to FIL-X414 Supply Pump	WX-P0004							MCC CP	DO	2.1	3	5	%M37
0040	0	P-X401.Flt	Fault	Filter Columns FIL-X411 to FIL-X414 Supply Pump	WX-P0004							MCC CP	DI	2.1	4	13	%I45
0041	0	P-X401.Run	Running	Filter Columns FIL-X411 to FIL-X414 Supply Pump	WX-P0004							MCC CP	DI	2.1	4	14	%I46
0042	0	P-X401.Auto	H-O-A In Auto	Filter Columns FIL-X411 to FIL-X414 Supply Pump	WX-P0004							MCC CP	DI	2.1	4	15	%I47
0043	0	P-X401.CmdSpeed	Speed Setpoint	Filter Columns FIL-X411 to FIL-X414 Supply Pump	WX-P0004	Hz	0	60				MCC CP	AO	2.1	7	4	%MW12
0044	1	P-X401.Speed	Speed Feedback	Filter Columns FIL-X411 to FIL-X414 Supply Pump	WX-P0004	Hz	0	60				MCC CP	AI	2.1	6	4	%IW67
0044A	1	P-X401.CmdSpeedA	Local Speed Setpoint	Filter Columns FIL-X411 to FIL-X414 Supply Pump	WX-P0004	%	0	100				PLC CP	AI	1.1	15	4	%IW58
0045	0	FI-X4110	Flow Indication	Filter Column FIL-411 Influent	WX-P0004	l/sec	0					PLC CP	AI	1.1	10	2	%IW11
0046	0	PDI-X4111	Differential Pressure Indication	Filter Column FIL-411	WX-P0004	kPA	0					PLC CP	AI	1.1	10	3	%IW12
0047	0	SOL-X4112.CmdOpn	Sample Line Solenoid	Filter Column FIL-411 Effluent	WX-P0004							PLC CP	DO	1.1	5	2	%M2
0048	0	FI-X4120	Flow Indication	Filter Column FIL-412 Influent	WX-P0004	l/sec	0					PLC CP	AI	1.1	10	4	%IW13
0049	0	PDI-X4121	Differential Pressure Indication	Filter Column FIL-412	WX-P0004	kPA	0					PLC CP	AI	1.1	10	5	%IW14
0050	0	SOL-X4122.CmdOpn	Sample Line Solenoid	Filter Column FIL-412 Effluent	WX-P0004							PLC CP	DO	1.1	5	3	%M3
0051	0	FI-X4200	Flow Indication	Filter Column FIL-411 to FIL-414 Influent	WX-P0004	l/sec	0					PLC CP	AI	1.1	10	6	%IW15
0052	0	AI-X4210	pH Indicator	Filter Column FIL-411 to FIL-414 Influent	WX-P0004	pH	0	14				PLC CP	AI	1.1	10	7	%IW16
0053	0	FI-X4130	Flow Indication	Filter Column FIL-413 Influent	WX-P0005	l/sec	0					PLC CP	AI	1.1	10	8	%IW17
0054	0	PDI-X4131	Differential Pressure Indication	Filter Column FIL-413	WX-P0005	kPA	0					PLC CP	AI	1.1	11	1	%IW19
0055	0	SOL-X4132.CmdOpn	Sample Line Solenoid	Filter Column FIL-413 Effluent	WX-P0005							PLC CP	DO	1.1	5	4	%M4
0056	0	FI-X4140	Flow Indication	Filter Column FIL-414 Influent	WX-P0005	l/sec	0					PLC CP	AI	1.1	11	2	%IW20
0057	0	PDI-X4141	Differential Pressure Indication	Filter Column FIL-414	WX-P0005	kPA	0					PLC CP	AI	1.1	11	3	%IW21
0058	0	SOL-X4142.CmdOpn	Sample Line Solenoid	Filter Column FIL-414 Effluent	WX-P0005							PLC CP	DO	1.1	5	5	%M5
0059	2	AI-X4240.Turb	Turbidity Indication	Filter Columns FIL-X411 to FIL-X414 Effluent	WX-P0005	NTU	0	1				PLC CP	AI	1.1	11	4	%IW22
0060	2	AI-X4250.PCBin1	Particle Count Bin 1 Indication	Filter Columns FIL-X411 to FIL-X414 Effluent	WX-P0005							PLC CP	AI	1.1	11	5	%IW23
0061	2	AI-X4250.PCBin2	Particle Count Bin 2 Indication	Filter Columns FIL-X411 to FIL-X414 Effluent	WX-P0005							PLC CP	AI	1.1	11	6	%IW24
0062	2	AI-X4250.PCBin3	Particle Count Bin 3 Indication	Filter Columns FIL-X411 to FIL-X414 Effluent	WX-P0005							PLC CP	AI	1.1	11	7	%IW25
0063	2	AI-X4250.PCBin4	Particle Count Bin 4 Indication	Filter Columns FIL-X411 to FIL-X414 Effluent	WX-P0005							PLC CP	AI	1.1	11	8	%IW26
0064	0	P-X402.CmdRun	Start/Stop	Filter Columns FIL-X415 to FIL-X418 Supply Pump	WX-P0006							MCC CP	DO	2.1	3	6	%M38
0065	0	P-X402.Flt	Fault	Filter Columns FIL-X415 to FIL-X418 Supply Pump	WX-P0006							MCC CP	DI	2.1	4	16	%I48
0066	0	P-X402.Run	Running	Filter Columns FIL-X415 to FIL-X418 Supply Pump	WX-P0006							MCC CP	DI	2.1	5	1	%I49
0067	0	P-X402.Auto	H-O-A In Auto	Filter Columns FIL-X415 to FIL-X418 Supply Pump	WX-P0006							MCC CP	DI	2.1	5	2	%I50
0068	0	P-X402.CmdSpeed	Speed Setpoint	Filter Columns FIL-X415 to FIL-X418 Supply Pump	WX-P0006	Hz	0	60				MCC CP	AO	2.1	8	1	%MW13

PLC I-O INDEX

RECORD NO.	REV. NO.	TAG NAME	DESCRIPTION		P&ID DRAWING	ENG. UNITS	SCALE		ALARMS		I/O SPECIFICATION					
			FUNCTION	SERVICE			LOW	HIGH	LOW	HIGH	PLC CABINET	I/O TYPE	I/O RACK	I/O CARD	I/O POINT	I/O ADDRESS
0069	1	P-X402.Speed	Speed Feedback	Filter Columns FIL-X415 to FIL-X418 Supply Pump	WX-P0006	Hz	0	60			MCC CP	AI	2.1	6	5	%IW68
0069A	1	P-X402.CmdSpeedA	Local Speed Setpoint	Filter Columns FIL-X415 to FIL-X418 Supply Pump	WX-P0006	%	0	100			PLC CP	AI	1.1	15	5	%IW59
0070	0	FI-X4150	Flow Indication	Filter Column FIL-415 Influent	WX-P0006	l/sec	0				PLC CP	AI	1.1	12	1	%IW28
0071	0	PDI-X4151	Differential Pressure Indication	Filter Column FIL-415	WX-P0006	kPA	0				PLC CP	AI	1.1	12	2	%IW29
0072	0	SOL-X4152.CmdOpn	Sample Line Solenoid	Filter Column FIL-415 Effluent	WX-P0006						PLC CP	DO	1.1	5	6	%M6
0073	0	FI-X4160	Flow Indication	Filter Column FIL-416 Influent	WX-P0006	l/sec	0				PLC CP	AI	1.1	12	3	%IW30
0074	0	PDI-X4161	Differential Pressure Indication	Filter Column FIL-416	WX-P0006	kPA	0				PLC CP	AI	1.1	12	4	%IW31
0075	0	SOL-X4162.CmdOpn	Sample Line Solenoid	Filter Column FIL-416 Effluent	WX-P0006						PLC CP	DO	1.1	5	7	%M7
0076	0	FI-X4220	Flow Indication	Filter Column FIL-415 to FIL-418 Influent	WX-P0006	l/sec	0				PLC CP	AI	1.1	12	5	%IW32
0077	0	AI-X4230.pH	pH Indicator	Filter Column FIL-415 to FIL-418 Influent	WX-P0006	pH	0	14			PLC CP	AI	1.1	12	6	%IW33
0078	0	FI-X4170	Flow Indication	Filter Column FIL-417 Influent	WX-P0007	l/sec	0				PLC CP	AI	1.1	12	7	%IW34
0079	0	PDI-X4171	Differential Pressure Indication	Filter Column FIL-417	WX-P0007	kPA	0				PLC CP	AI	1.1	12	8	%IW35
0080	0	SOL-X4172.CmdOpn	Sample Line Solenoid	Filter Column FIL-417 Effluent	WX-P0007						PLC CP	DO	1.1	5	8	%M8
0081	0	FI-X4180	Flow Indication	Filter Column FIL-418 Influent	WX-P0007	l/sec	0				PLC CP	AI	1.1	13	1	%IW37
0082	0	PDI-X4181	Differential Pressure Indication	Filter Column FIL-418	WX-P0007	kPA	0				PLC CP	AI	1.1	13	2	%IW38
0083	0	SOL-X4182.CmdOpn	Sample Line Solenoid	Filter Column FIL-418 Effluent	WX-P0007						PLC CP	DO	1.1	5	9	%M9
0084	2	AI-X4260.Turb	Turbidity Indication	Filter Columns FIL-X415 to FIL-X418 Effluent	WX-P0007	NTU	0	1			PLC CP	AI	1.1	13	3	%IW39
0085	2	AI-X4270.PCBin1	Particle Count Bin 1 Indication	Filter Columns FIL-X415 to FIL-X418 Effluent	WX-P0007						PLC CP	AI	1.1	13	4	%IW40
0086	2	AI-X4270.PCBin2	Particle Count Bin 2 Indication	Filter Columns FIL-X415 to FIL-X418 Effluent	WX-P0007						PLC CP	AI	1.1	13	5	%IW41
0087	2	AI-X4270.PCBin3	Particle Count Bin 3 Indication	Filter Columns FIL-X415 to FIL-X418 Effluent	WX-P0007						PLC CP	AI	1.1	13	6	%IW42
0088	2	AI-X4270.PCBin4	Particle Count Bin 4 Indication	Filter Columns FIL-X415 to FIL-X418 Effluent	WX-P0007						PLC CP	AI	1.1	13	7	%IW43
0089	0	P-X403.CmdRun	Start/Stop	Backwash Supply Pump	WX-P0007						MCC CP	DO	2.1	3	7	%M39
0090	0	P-X403.Flt	Fault	Backwash Supply Pump	WX-P0007						MCC CP	DI	2.1	5	3	%I51
0091	0	P-X403.Run	Running	Backwash Supply Pump	WX-P0007						MCC CP	DI	2.1	5	4	%I52
0092	0	P-X403.Auto	H-O-A In Auto	Backwash Supply Pump	WX-P0007						MCC CP	DI	2.1	5	5	%I53
0093	0	P-X403.Start	Field Start PB	Backwash Supply Pump	WX-P0007						PLC CP	DI	1.1	7	4	%I4
0094	0	P-X403.Stop	Field Stop PB	Backwash Supply Pump	WX-P0007						PLC CP	DI	1.1	7	5	%I5
0095	0	LI-X4101	Level Indication	Backwash Supply Tank	WX-P0007	mm	0	3000			PLC CP	AI	1.1	13	8	%IW44
0096	2	AI-X4101.pH	pH Indicator	Filter Column Effluent	WX-P0007	pH	0	14			PLC CP	AI	1.1	14	1	%IW46
0097	0	P-X501.CmdRun	Start/Stop	Sulphuric Acid Metering Pump	WX-P0008						PLC CP	DO	1.1	5	10	%M10
0098	0	P-X501.Flt	Fault	Sulphuric Acid Metering Pump	WX-P0008						PLC CP	DI	1.1	7	6	%I6
0099	0	P-X501.CmdSpeed	Speed Setpoint	Sulphuric Acid Metering Pump	WX-P0008	ml/min	0	500			PLC CP	AO	1.2	2	2	%MW2
0100	0	P-X502.CmdRun	Start/Stop	Ferric Chloride Metering Pump	WX-P0008						PLC CP	DO	1.1	5	11	%M11
0101	0	P-X502.Flt	Fault	Ferric Chloride Metering Pump	WX-P0008						PLC CP	DI	1.1	7	7	%I7
0102	0	P-X502.CmdSpeed	Speed Setpoint	Ferric Chloride Metering Pump	WX-P0008	ml/min	0	500			PLC CP	AO	1.2	2	3	%MW3
0103	0	P-X503.CmdRun	Start/Stop	Hydrogen Peroxide Metering Pump	WX-P0008						PLC CP	DO	1.1	5	12	%M12
0104	0	P-X503.Flt	Fault	Hydrogen Peroxide Metering Pump	WX-P0008						PLC CP	DI	1.1	7	8	%I8
0105	0	P-X503.CmdSpeed	Speed Setpoint	Hydrogen Peroxide Metering Pump	WX-P0008	ml/min	0	9			PLC CP	AO	1.2	2	4	%MW4

PLC I-O INDEX

RECORD NO.	REV. NO.	TAG NAME	DESCRIPTION		I/O SPECIFICATION												
					P&ID DRAWING	ENG. UNITS	SCALE		ALARMS		PLC CABINET	I/O TYPE	I/O RACK	I/O CARD	I/O POINT	I/O ADDRESS	
0106	0	P-X504.CmdRun	Start/Stop	Sodium Bisulphite Metering Pump	WX-P0008							PLC CP	DO	1.1	5	13	%M13
0107	0	P-X504.Flt	Fault	Sodium Bisulphite Metering Pump	WX-P0008							PLC CP	DI	1.1	7	9	%I9
0108	0	P-X504.CmdSpeed	Speed Setpoint	Sodium Bisulphite Metering Pump	WX-P0008	ml/min	0	9				PLC CP	AO	1.2	3	1	%MW5
0109	0	P-X505.CmdRun	Start/Stop	Filter Aid Metering Pump	WX-P0009							PLC CP	DO	1.1	5	14	%M14
0110	0	P-X505.Flt	Fault	Filter Aid Metering Pump	WX-P0009							PLC CP	DI	1.1	7	10	%I10
0111	1	P-X505.CmdSpeed	Speed Setpoint	Filter Aid Metering Pump	WX-P0009	ml/min	0	1.25				PLC CP	AO	1.2	3	2	%MW6
0112	0	P-X506.CmdRun	Start/Stop	Filter Aid Metering Pump	WX-P0009							PLC CP	DO	1.1	5	15	%M15
0113	0	P-X506.Flt	Fault	Filter Aid Metering Pump	WX-P0009							PLC CP	DI	1.1	7	11	%I11
0114	0	P-X506.CmdSpeed	Speed Setpoint	Filter Aid Metering Pump	WX-P0009	ml/min	0	1.25				PLC CP	AO	1.2	3	3	%MW7
0115	0	P-X507.CmdRun	Start/Stop	Caustic Soda Metering Pump	WX-P0009							PLC CP	DO	1.1	5	16	%M16
0116	0	P-X507.Flt	Fault	Caustic Soda Metering Pump	WX-P0009							PLC CP	DI	1.1	7	12	%I12
0117	0	P-X507.CmdSpeed	Speed Setpoint	Caustic Soda Metering Pump	WX-P0009	ml/min	0					PLC CP	AO	1.2	3	4	%MW8
0118	0	P-X508.CmdRun	Start/Stop	Caustic Soda Metering Pump	WX-P0009							PLC CP	DO	1.1	6	1	%M17
0119	0	P-X508.Flt	Fault	Caustic Soda Metering Pump	WX-P0009							PLC CP	DI	1.1	7	13	%I13
0120	0	P-X508.CmdSpeed	Speed Setpoint	Caustic Soda Metering Pump	WX-P0009	ml/min	0					PLC CP	AO	1.2	4	1	%MW9
0121	0	SOL-X3010.CmdOpn	Service Water Solenoid	Ozone Generator G-X330	WX-P0010							PLC CP	DO	1.1	6	2	%M18
0122	0	G-X330.CmdRun	Start/Stop	Ozone Generator G-X330	WX-P0010							PLC CP	DO	1.1	6	3	%M19
0123	0	G-X330.Flt	Fault	Ozone Generator G-X330	WX-P0010							PLC CP	DI	1.1	7	14	%I14
0124	0	G-X331.CmdRun	Start/Stop	Ozone Destruct G-X331	WX-P0010							PLC CP	DO	1.1	6	4	%M20
0125	0	G-X331.Flt	Fault	Ozone Destruct G-X331	WX-P0010							PLC CP	DI	1.1	7	15	%I15
0126	0	AI-X6020.O3	Ozone	Ambient Monitor	WX-P0010	ppm	0	20				PLC CP	AI	1.1	14	2	%IW47
0127	0	AI-X6030.O3	Ozone	Ambient Monitor	WX-P0010	ppm	0	20				PLC CP	AI	1.1	14	3	%IW48
0128	0	AI-X3310.O3	Ozone	Ambient Monitor	WX-P0010	ppm	0	20				PLC CP	AI	1.1	14	4	%IW49
0129	0	FA-X6050	Flow Alarm	Emergency Shower	WX-H0122							PLC CP	DI	1.1	7	16	%I16
0130	1	JA-CPX101	Power Fail Alarm	Normal Power Supply								PLC CP	DI	1.1	8	17	%I17
0131	1	JA-CPX102	Power Fail Alarm	24 VDC Power Supply								PLC CP	DI	1.1	8	18	%I18
0132	2	HS-X3310	Field Stop PB	Ozone Generator G-X330								PLC CP	DI	1.1	8	19	%I19
0133	2	FQ-X4200	Flow Totalization	Filter Column FIL-411 to FIL-414 Influent	WX-P0004	m^3						PLC CP	DI	1.1	8	20	%I20
0134	2	FQ-X4220	Flow Totalization	Filter Column FIL-415 to FIL-418 Influent	WX-P0006	m^3						PLC CP	DI	1.1	8	21	%I21
0135	3	FA-X5100	Flow Switch	Sulphuric Acid Injection Point 1	WX-P0001							PLC CP	DI	1.1	8	22	%I22
0136	3	FA-X5101	Flow Switch	Sulphuric Acid Injection Point 2	WX-P0001							PLC CP	DI	1.1	8	23	%I23
0137	3	FA-X5110	Flow Switch	Ferric Chloride Injection Point 1	WX-P0001							PLC CP	DI	1.1	8	24	%I24
0138	3	FA-X5111	Flow Switch	Ferric Chloride Injection Point 2	WX-P0001							PLC CP	DI	1.1	8	25	%I25
0139	3	FA-X5120	Flow Switch	Caustic Soda Injection Point 1	WX-P0002							PLC CP	DI	1.1	8	26	%I26
0140	3	FA-X5121	Flow Switch	Caustic Soda Injection Point 2	WX-P0002							PLC CP	DI	1.1	8	27	%I27
0141	3	FA-X5122	Flow Switch	Caustic Soda Injection Point 3	WX-P0004							PLC CP	DI	1.1	8	28	%I28
0142	3	FA-X5123	Flow Switch	Caustic Soda Injection Point 4	WX-P0006							PLC CP	DI	1.1	8	29	%I29
0143	0	Spare-DI.30										PLC CP	DI	1.1	8	30	%I30
0144	0	Spare-DI.31										PLC CP	DI	1.1	8	31	%I31
0145	0	Spare-DI.32										PLC CP	DI	1.1	8	32	%I32
0146	0	Spare-DO.21										PLC CP	DO	1.1	6	5	%M21
0147	0	Spare-DO.22										PLC CP	DO	1.1	6	6	%M22
0148	0	Spare-DO.23										PLC CP	DO	1.1	6	7	%M23
0149	0	Spare-DO.24										PLC CP	DO	1.1	6	8	%M24

PLC I-O INDEX

RECORD NO.	REV. NO.	TAG NAME	DESCRIPTION		P&ID DRAWING	ENG. UNITS	SCALE		ALARMS		I/O SPECIFICATION					
			FUNCTION	SERVICE			LOW	HIGH	LOW	HIGH	PLC CABINET	I/O TYPE	I/O RACK	I/O CARD	I/O POINT	I/O ADDRESS
0150	0	Spare-DO.25									PLC CP	DO	1.1	6	9	%M25
0151	0	Spare-DO.26									PLC CP	DO	1.1	6	10	%M26
0152	0	Spare-DO.27									PLC CP	DO	1.1	6	11	%M27
0153	0	Spare-DO.28									PLC CP	DO	1.1	6	12	%M28
0154	0	Spare-DO.29									PLC CP	DO	1.1	6	13	%M29
0155	0	Spare-DO.30									PLC CP	DO	1.1	6	14	%M30
0156	0	Spare-DO.31									PLC CP	DO	1.1	6	15	%M31
0157	0	Spare-DO.32									PLC CP	DO	1.1	6	16	%M32
0158	1	Spare-AI.53									PLC CP	AI	1.1	14	8	%IW53
0159	1	Spare-AI.51														
0160	1	Spare-AI.52														
0161	1	Spare-AI.60									PLC CP	AI	1.1	15	6	%IW60
0161A	1	Spare-AI.61									PLC CP	AI	1.1	15	7	%IW61
0161B	1	Spare-AI.62									PLC CP	AI	1.1	15	8	%IW62
0161C	1	Spare-AI.53														
0162	0	Spare-AO.7									PLC CP	AO	1.2	4	2	%MW10
0163	0	Spare-AO.8									PLC CP	AO	1.2	4	3	%MW11
0164	0	Spare-AO.9									PLC CP	AO	1.2	4	4	%MW12
0168	1	JA-CPH10B1	Power Fail Alarm	Normal Power Supply							MCC CP	DI	2.1	5	6	%I54
0169	1	JA-CPH10B2	Power Fail Alarm	24 VDC Power Supply							MCC CP	DI	2.1	5	7	%I55
0170	0	Spare-DI.56									MCC CP	DI	2.1	5	8	%I56
0171	0	Spare-DI.57									MCC CP	DI	2.1	5	9	%I57
0172	0	Spare-DI.58									MCC CP	DI	2.1	5	10	%I58
0173	0	Spare-DI.59									MCC CP	DI	2.1	5	11	%I59
0174	0	Spare-DI.60									MCC CP	DI	2.1	5	12	%I60
0175	0	Spare-DI.61									MCC CP	DI	2.1	5	13	%I61
0176	0	Spare-DI.62									MCC CP	DI	2.1	5	14	%I62
0177	0	Spare-DI.63									MCC CP	DI	2.1	5	15	%I63
0178	0	Spare-DI.64									MCC CP	DI	2.1	5	16	%I64
0179	0	Spare_DO.40									MCC CP	DO	2.1	3	8	%M40
0180	0	Spare_DO.41									MCC CP	DO	2.1	3	9	%M41
0181	0	Spare_DO.42									MCC CP	DO	2.1	3	10	%M42
0182	0	Spare_DO.43									MCC CP	DO	2.1	3	11	%M43
0183	0	Spare_DO.44									MCC CP	DO	2.1	3	12	%M44
0184	0	Spare_DO.45									MCC CP	DO	2.1	3	13	%M45
0185	0	Spare_DO.46									MCC CP	DO	2.1	3	14	%M46
0186	0	Spare_DO.47									MCC CP	DO	2.1	3	15	%M47
0187	0	Spare_DO.48									MCC CP	DO	2.1	3	16	%M48
0188	1	Spare-AI.69									MCC CP	AI	2.1	6	6	%IW69
0189	1	Spare-AI.70									MCC CP	AI	2.1	6	7	%IW70
0190	1	Spare-AI.71									MCC CP	AI	2.1	6	8	%IW71
0191	0	Spare-AO.14									MCC CP	AO	2.1	8	2	%MW14
0192	0	Spare-AO.15									MCC CP	AO	2.1	8	3	%MW15
0193	0	Spare-AO.16									MCC CP	AO	2.1	8	4	%MW16

SECTION 29 40 21

INSTRUMENTATION INDEX

PART 1 GENERAL

1.1 REFERENCES - GENERAL

- A. Refer to Section 29 05 00, Common Work Instrumentation.

1.2 INSTRUMENT INDEX

- A. Instrumentation shall be supplied by the City and installed by the Contractor.
- B. The supplements listed below, following “End of Section” are part of this Specification.
 - 1. The following spreadsheet gives an itemized list of the instrumentation required for completed project

PART 2 PRODUCTS (Not Used)

PART 3 EXECUTION

3.1 SUPPLEMENTS

- A. The supplements listed below, following “End of Section” are part of this Specification.
 - 1. Instrumentation FE/FIT-X1020 Loop Diagram
 - 2. Instrumentation FIT-X4110 Loop Diagram
 - 3. Instrumentation LE/LIT-X2100 Loop Diagram
 - 4. Instrumentation LS-X6010 Loop Diagram
 - 5. Instrumentation PDIT-X4111 Loop Diagram
 - 6. Instrumentation SOL-X202 Loop Diagram
 - 7. Instrumentation AE/AIT-X1022 Loop Diagram
 - 8. Instrumentation AE/AIT-X3100 Loop Diagram
 - 9. Instrumentation AIT-X3302 Loop Diagram
 - 10. Instrumentation CP-H10B Normal Power Supply
 - 11. Instrumentation CP-H10B 24 VDC Power Supply
 - 12. Instrumentation CP-H10B UPS Power Supply
 - 13. Instrumentation CP-X10 Normal Power Supply
 - 14. Instrumentation CP-X10 24 VDC Power Supply
 - 15. Instrumentation CP-X10 UPS Power Supply
 - 16. Instrumentation P-X403 Loop Diagram
 - 17. Instrumentation P-X201 Loop Diagram
 - 18. Instrumentation AIT-X6020 Loop Diagram
 - 19. Instrumentation FS-X6050 Loop Diagram
 - 20. Instrumentation AIT-X4111 Loop Diagram

21. Instrumentation P-X101 Loop Diagram
22. Instrumentation G-X330 Loop Diagram
23. Instrumentation G-X331 Loop Diagram
24. Instrumentation P-X501 Loop Diagram

END OF SECTION

INSTRUMENTATION INDEX

RECORD NO.	REV. No.	LOOP NUM.	TAG NAME	DESCRIPTION		MANUFACTURER	MODEL	POWER SUPPLY	CALIBRATED RANGE	MOUNTING	SUPPLIED BY	INSTALLED BY	COMMENTS	SPEC. DATA SHEET	P&ID DRAWING	LOCATION DWG.
				INSTRUMENT TYPE	SERVICE											
0001	0	1010	FV-X1010	Flow Control Valve	Raw Water Supply			120 VAC	0 - 100%		City	Contractor			WX-P0001	WX-E0121
0002	0	1011	PG-X1011	Pressure Gauge	Raw Water Supply	Ashcroft	1259		0 - 1000 kPa		City	Contractor		I-105	WX-P0001	
0003	0	1020	FE/FIT-X1020	Magnetic Flow Transmitter	Raw Water Supply	Endress & Hauser	Promag 53W, 150 mm flow tube	120 VAC	0 - 100 l/sec		City	Contractor	Remote mount transmitter	I-101	WX-P0001	WX-E0121
0004	0	1021	PG-X1021	Pressure Gauge	Raw Water Supply - DAF Train	Ashcroft	1259		0 - 1000 kPa		City	Contractor		I-105	WX-P0001	
0005	0	1022	AE/AIT-X1022	pH Transmitter	DAF Influent	Endress & Hauser	Probe: CPS11 Transmitter: CPM253	120 VAC	0 - 14 pH		City	Contractor		I-111	WX-P0001	WX-E0121
0006	0	2101	FI-X2101	Flow Indicator	DAF Influent	Yokogawa	RAMC15		0 - 130 m3/h		City	Contractor		I-113	WX-P0001	
0007	0	6010	LS-X6010	Level Switch	Building Flood	Endress & Hauser	Liquiphant T	Loop Powered			City	Contractor	Mount 15 mm above floor	I-108	WX-P0001	WX-E0121
0008	0	21001	SC-X21001	DC Drive Speed Controller	DAF Tank Mixer	Reliance	DC2	120 VAC	0 - 100%		Existing	Contractor	Provide cord and cap and receptacle		WX-P0002	WX-E0121
0009	0	21002	SC-X21002	DC Drive Speed Controller	DAF Tank Mixer	Reliance	DC2	120 VAC	0 - 100%		Existing	Contractor	Provide cord and cap and receptacle		WX-P0002	WX-E0121
0010	0	21003	SC-X21003	DC Drive Speed Controller	DAF Tank Mixer	Reliance	DC2	120 VAC	0 - 100%		Existing	Contractor	Provide cord and cap and receptacle		WX-P0002	WX-E0121
0011	0	21004	SC-X21004	DC Drive Speed Controller	DAF Tank Scrapper	Reliance	DC2	120 VAC	0 - 100%		City	Contractor	Provide cord and cap and receptacle		WX-P0002	WX-E0121
0012	0	2100	LE/LIT-X2100	Level Transmitter	DAF Tank	Endress & Hauser	FMU40	Loop Powered	0 - 3000 mm		City	Contractor		I-107	WX-P0002	WX-E0121
0013	0	2011	PG-X2011	Pressure Gauge	DAF Recycle Pump Discharge	Ashcroft	1259		0 - 1000 kPa		City	Contractor		I-105	WX-P0002	
0014	0	2012	FE/FIT-X2012	Magnetic Flow Transmitter	DAF Recycle	Endress & Hauser	Promag 53W, 50 mm flow tube	120 VAC	0 - 2 l/sec		Existing	Contractor			WX-P0002	
0015	0	2201	FI-X2201	Flow Indicator	DAF Saturator Tank Compressed Air Supply	Yokogawa	RAGN01		0 - 14 l/sec		City	Contractor		I-103	WX-P0002	
0016	0	202	SOL-X202	Solenoid Valve	DAF Saturator Tank Compressed Air Supply	ASCO	8210G007	120 VAC		NPT	City	Contractor		I-115	WX-P0002	WX-E0121
0017	0	2202	PG-X2202	Pressure Gauge	DAF Saturator Tank Compressed Air Supply	Ashcroft	1259		0 - 1000 kPa		City	Contractor		I-106	WX-P0002	
0018	0	310	AE/AIT-X3100	Turbidity Transmitter	DAF Effluent	Endress & Hauser	Turbimax CUE21	120 VAC	0 - 10 NTU		City	Contractor		I-109	WX-P0002	WX-E0121
0019	0	2110	LE/LIT-X2110	Level Transmitter	TK-X203	Endress & Hauser	FMU	Loop Powered	0 - 3000 mm		City	Contractor		I-107	WX-P0002	WX-E0121
0020	0	3150	AE/AIT-X3150	pH Transmitter	DAF Influent	Endress & Hauser	Probe: CPS11 Transmitter: CPM253	120 VAC	0 - 14 pH		City	Contractor		I-111	WX-P0002	WX-E0121
0021	0	3160	AE/AIT-X3160	pH Transmitter	DAF Influent	Endress & Hauser	Probe: CPS11 Transmitter: CPM253	120 VAC	0 - 14 pH		City	Contractor		I-111	WX-P0002	WX-E0121
0022	0	3011	FI-X3011	Flow Indicator	Ozone Contactor TK-X301 Influent	Yokogawa	RAGN01-A1-SS		0 - 2 l/sec		City	Contractor		I-114	WX-P0003	
0023	0	3021	FI-X3021	Flow Indicator	Ozone Contactor TK-X302 Influent	Yokogawa	RAGN01-A1-SS		0 - 2 l/sec		City	Contractor		I-114	WX-P0003	

INSTRUMENTATION INDEX

RECORD NO.	REV. No.	LOOP NUM.	TAG NAME	DESCRIPTION		MANUFACTURER	MODEL	POWER SUPPLY	CALIBRATED RANGE	MOUNTING	SUPPLIED BY	INSTALLED BY	COMMENTS	SPEC. DATA SHEET	P&ID DRAWING	LOCATION DWG.
				INSTRUMENT TYPE	SERVICE											
0024	0	3200	LE/LIT-X3200	Level Transmitter	Ozonated Water Holding Tank TK-X303	Endress & Hauser	FMU	Loop Powered	0 - 3000 mm		City	Contractor		I-107	WX-P0003	WX-E0121
0025	0	3201	PG-X3201	Pressure Gauge	Ozonated Water	Ashcroft	1259		0 - 400 kPa		City	Contractor		I-106	WX-P0003	
0026	0	3202	AE/AIT-X3202	Dissolved Ozone Transmitter	Ozonated Water	Rosemont	1056-03-26-38-AN	120 VAC	0 - 3 ppm		City	Contractor		I-116	WX-P0003	WX-E0121
0027	0	2211	FI-X2211	Flow Indicator	Filter Air Scour Compressed Air Supply	Yokogawa	RAGN01		0 - 14 l/sec		City	Contractor		I-103	WX-P0004	
0028	0	2212	PG-X2212	Pressure Gauge	Filter Air Scour Compressed Air Supply	Ashcroft	1259		0 - 1000 kPa		City	Contractor		I-106	WX-P0004	
0029	0	4200	FE/FIT-X4200	Magnetic Flow Transmitter	Filter X411 to X414 Influent	Endress & Hauser	Promag 53W, 25 mm flow tube	120 VAC	0 - 2 l/sec		City	Contractor	Remote mount transmitter	I-101	WX-P0004	WX-E0121
0030	0	4210	AE/AIT-X4210	pH Transmitter	Filter X411 to X414 Influent	Endress & Hauser	Probe: CPS11 Transmitter: CPM253	120 VAC	0 - 14 pH		City	Contractor		I-111	WX-P0004	WX-E0121
0031	0	4110	FIT-X4110	Paddle Wheel Flow Transmitter	Filter FIL-X411 Influent	George Fdischer Signet	8550 & 8512	Loop Powered	0 - 0.5 l/sec		City	Contractor		I-102	WX-P0004	WX-E0121
0032	0	4111	PDIT-X4111	Differential Pressure Transmitter	Filter FIL-X411	Rosemont		Loop Powered	0 - 200 kPa		Existing	Contractor			WX-P0004	WX-E0121
0033	0	411	SOL-X411	Solenoid Valve	Filter FIL-X411 Effluent Sample Line	ASCO	8210G007	120 VAC		NPT	City	Contractor		I-115	WX-P0004	WX-E0121
0034	0	4120	FIT-X4120	Paddle Wheel Flow Transmitter	Filter FIL-X412 Influent	George Fdischer Signet	8550 & 8512	Loop Powered	0 - 0.5 l/sec		City	Contractor		I-102	WX-P0004	WX-E0121
0035	0	4121	PDIT-X4121	Differential Pressure Transmitter	Filter FIL-X412	Rosemont		Loop Powered	0 - 200 kPa		Existing	Contractor			WX-P0004	WX-E0121
0036	0	412	SOL-X412	Solenoid Valve	Filter FIL-X412 Effluent Sample Line	ASCO	8210G007	120 VAC		NPT	City	Contractor		I-115	WX-P0004	WX-E0121
0037	0	4130	FIT-X4130	Paddle Wheel Flow Transmitter	Filter FIL-X413 Influent	George Fdischer Signet	8550 & 8512	Loop Powered	0 - 0.5 l/sec		City	Contractor		I-102	WX-P0005	WX-E0121
0038	0	4131	PDIT-X4131	Differential Pressure Transmitter	Filter FIL-X413	Rosemont		Loop Powered	0 - 200 kPa		Existing	Contractor			WX-P0005	WX-E0121
0039	0	413	SOL-X413	Solenoid Valve	Filter FIL-X413 Effluent Sample Line	ASCO	8210G007	120 VAC		NPT	City	Contractor		I-115	WX-P0005	WX-E0121
0040	0	4140	FIT-X4140	Paddle Wheel Flow Transmitter	Filter FIL-X414 Influent	George Fdischer Signet	8550 & 8512	Loop Powered	0 - 0.5 l/sec		City	Contractor		I-102	WX-P0005	WX-E0121
0041	0	4141	PDIT-X4141	Differential Pressure Transmitter	Filter FIL-X414	Rosemont		Loop Powered	0 - 200 kPa		Existing	Contractor			WX-P0005	WX-E0121
0042	0	414	SOL-X414	Solenoid Valve	Filter FIL-X414 Effluent Sample Line	ASCO	8210G007	120 VAC		NPT	City	Contractor		I-115	WX-P0005	WX-E0121
0043	1	4240	AE/AIT-X4240	Turbidity Transmitter	Filters FIL-X411 to FIL-X414 Effluent Sample Line	Endress & Hauser	Turbimax CUE21	120 VAC			City	Contractor		I-109	WX-P0005	WX-E0121
0044	1	4250	AE/AIT-X4250	Particle Counter	Filters FIL-X411 to FIL-X414 Effluent Sample Line	HACH	2200	120 VAC			City	Contractor		I-110	WX-P0005	WX-E0121

INSTRUMENTATION INDEX

RECORD NO.	REV. No.	LOOP NUM.	TAG NAME	DESCRIPTION		MANUFACTURER	MODEL	POWER SUPPLY	CALIBRATED RANGE	MOUNTING	SUPPLIED BY	INSTALLED BY	COMMENTS	SPEC. DATA SHEET	P&ID DRAWING	LOCATION DWG.
				INSTRUMENT TYPE	SERVICE											
0045	0	4220	FE/FIT-X4220	Magnetic Flow Transmitter	Filter X415 to X418 Influent	Endress & Hauser	Promag 53W, 25 mm flow tube	120 VAC	0 - 2 l/sec		City	Contractor	Remote mount transmitter	I-101	WX-P0006	WX-E0121
0046	0	4230	AE/AIT-X4230	pH Transmitter	Filter X415 to X418 Influent	Endress & Hauser	Probe: CPS11 Transmitter: CPM253	120 VAC	0 - 14 pH		City	Contractor		I-111	WX-P0006	WX-E0121
0047	0	4150	FIT-X4150	Paddle Wheel Flow Transmitter	Filter FIL-X415 Influent	George Fdischer Signet	8550 & 8512	Loop Powered	0 - 0.5 l/sec		City	Contractor		I-102	WX-P0006	WX-E0121
0048	0	4151	PDIT-X4151	Differential Pressure Transmitter	Filter FIL-X415	Rosemont		Loop Powered	0 - 200 kPa		Existing	Contractor			WX-P0006	WX-E0121
0049	0	415	SOL-X415	Solenoid Valve	Filter FIL-X415 Effluent Sample Line	ASCO	8210G007	120 VAC		NPT	City	Contractor		I-115	WX-P0006	WX-E0121
0050	0	4160	FIT-X4160	Paddle Wheel Flow Transmitter	Filter FIL-X416 Influent	George Fdischer Signet	8550 & 8512	Loop Powered	0 - 0.5 l/sec		City	Contractor		I-102	WX-P0006	WX-E0121
0051	0	4161	PDIT-X4161	Differential Pressure Transmitter	Filter FIL-X416	Rosemont		Loop Powered	0 - 200 kPa		Existing	Contractor			WX-P0006	WX-E0121
0052	0	416	SOL-X416	Solenoid Valve	Filter FIL-X416 Effluent Sample Line	ASCO	8210G007	120 VAC		NPT	City	Contractor		I-115	WX-P0006	WX-E0121
0053	0	4170	FIT-X4170	Paddle Wheel Flow Transmitter	Filter FIL-X417 Influent	George Fdischer Signet	8550 & 8512	Loop Powered	0 - 0.5 l/sec		City	Contractor		I-102	WX-P0007	WX-E0121
0054	0	4171	PDIT-X4171	Differential Pressure Transmitter	Filter FIL-X417	Rosemont		Loop Powered	0 - 200 kPa		Existing	Contractor			WX-P0007	WX-E0121
0055	0	417	SOL-X417	Solenoid Valve	Filter FIL-X417 Effluent Sample Line	ASCO	8210G007	120 VAC		NPT	City	Contractor		I-115	WX-P0007	WX-E0121
0056	0	4180	FIT-X4180	Paddle Wheel Flow Transmitter	Filter FIL-X418 Influent	George Fdischer Signet	8550 & 8512	Loop Powered	0 - 0.5 l/sec		City	Contractor		I-102	WX-P0007	WX-E0121
0057	0	4181	PDIT-X4181	Differential Pressure Transmitter	Filter FIL-X418	Rosemont		Loop Powered	0 - 200 kPa		Existing	Contractor			WX-P0007	WX-E0121
0058	0	418	SOL-X418	Solenoid Valve	Filter FIL-X418 Effluent Sample Line	ASCO	8210G007	120 VAC		NPT	City	Contractor		I-115	WX-P0007	WX-E0121
0059	1	4101	AE/AIT-X4101	pH Transmitter	Filter X411 to X418 Effluent	Endress & Hauser	Probe: CPS11 Transmitter: CPM253	120 VAC	0 - 14 pH		City	Contractor		I-111	WX-P0007	WX-E0121
0060	0	4101	LE/LIT-X4101	Level Transmitter	Filtered Water Tank TK-X410			120 VAC			City	Contractor		I-107	WX-P0007	WX-E0121
0061	1	4260	AE/AIT-X4260	Turbidity Transmitter	Filters FIL-X415 to FIL-X418 Effluent Sample Line	Endress & Hauser	Turbimax CUE21	120 VAC			City	Contractor		I-109	WX-P0007	WX-E0121
0062	1	4270	AE/AIT-X4270	Particle Counter	Filters FIL-X415 to FIL-X418 Effluent Sample Line	HACH	2200	120 VAC			City	Contractor		I-110	WX-P0007	WX-E0121
0063	0	301	SOL-X301	Solenoid Valve	Ozone Generator Service Water	ASCO	8210G007	120 VAC		NPT	City	Contractor			WX-P0010	WX-E0121
0064	0	3301	FI-X3301	Flow Indicator	Ozone Generator Service Water	Yokogawa	RAGN01-A1-SS		0 - 1 l/sec		City	Contractor		I-114	WX-P0010	
0065	0	3211	TI-X3211	Temperature Indicator	Ozone Contactor TK-X321 Supply	Ashcroft	20-CI-60		0 - 100 °C	Thermowell	City	Contractor		I-104	WX-P0010	

INSTRUMENTATION INDEX

RECORD NO.	REV. No.	LOOP NUM.	TAG NAME	DESCRIPTION		MANUFACTURER	MODEL	POWER SUPPLY	CALIBRATED RANGE	MOUNTING	SUPPLIED BY	INSTALLED BY	COMMENTS	SPEC. DATA SHEET	P&ID DRAWING	LOCATION DWG.
				INSTRUMENT TYPE	SERVICE											
0066	0	3212	FI-X3212	Flow Indicator	Ozone Contactor TK-X321 Supply	Yokogawa	RAGN01		0 - 2 l/sec		City	Contractor		I-103	WX-P0010	
0067	0	3213	PG-X3213	Pressure Gauge	Ozone Contactor TK-X321 Supply	Ashcroft	1259		0 - 400 kPa		City	Contractor		I-106	WX-P0010	
0068	0	3221	TI-X3221	Temperature Indicator	Ozone Contactor TK-X322 Supply	Ashcroft	20-CI-60		0 - 100 °C	Thermowell	City	Contractor		I-104	WX-P0010	
0069	0	3222	FI-X3222	Flow Indicator	Ozone Contactor TK-X322 Supply	Yokogawa	RAGN01				City	Contractor		I-103	WX-P0010	
0070	0	3223	PG-X3223	Pressure Gauge	Ozone Contactor TK-X322 Supply	Ashcroft	1259		0 - 400 kPa		City	Contractor		I-106	WX-P0010	
0071	0	3310	AE/AIT-X3310	Ozone Transmitter	Ozone Off Gas	InUSA	IN-2000-L2-LC	120 VAC			City	Contractor		I-112	WX-P0010	WX-E0121
0072	0	6020	AE/AIT-X6020	Ozone Transmitter	Ambient Ozone	InUSA	IN-2000-L2-LC	120 VAC			City	Contractor		I-112	WX-P0010	WX-E0121
0073	0	6030	AE/AIT-X6030	Ozone Transmitter	Ambient Ozone	InUSA	IN-2000-L2-LC	120 VAC			City	Contractor		I-112	WX-P0010	WX-E0121
0074	0	3311	FI-X3311	Flow Indicator	Ozone Off Gas	Yokogawa	RAGN01				City	Contractor		I-103	WX-P0010	
0075	0	3312	FI-X3312	Flow Indicator	Ozone Off Gas	Yokogawa	RAGN01				City	Contractor		I-103	WX-P0010	
0076	2	6050	FS-X6050	Flow Switch	Emergency Shower	Magnetrol	TEM-A210-001				Contractor	Contractor		I-117	WX-H0122	WX-E0121
0077	1	4031	PG-X4031	Pressure Gauge	Backwash Supply Pump Discharge	Ashcroft	1259		0 - 1000 kPa		City	Contractor		I-105	WX-P0007	
0078	1	60201	HAH-X60201	Indicator Lamp	Ambient Ozone High Level	Schneider Electric	XVBC2G5	120 VAC			City	Contractor		I-119	WX-P0010	
0079	1	60202	HAH-X60202	Indicator Lamp	Ambient Ozone Hi Level	Schneider Electric	XVBC2G4	120 VAC			City	Contractor		I-119	WX-P0010	
0080	1	60203	HAH-X60203	Buzzer	Ambient Ozone Hi Level	Schneider Electric	XVBC9M	120 VAC			City	Contractor		I-119	WX-P0010	
0081	1	60301	HAH-X60301	Indicator Lamp	Ambient Ozone High Level	Schneider Electric	XVBC2G5	120 VAC			City	Contractor		I-119	WX-P0010	
0082	1	60302	HAH-X60302	Indicator Lamp	Ambient Ozone Hi Level	Schneider Electric	XVBC2G4	120 VAC			City	Contractor		I-119	WX-P0010	
0083	1	60303	HAH-X60303	Buzzer	Ambient Ozone Hi Level	Schneider Electric	XVBC9M	120 VAC			City	Contractor		I-119	WX-P0010	
0084	1	6051	TI-X6051	Temperature Indicator	Emergency Shower Supply	Ashcroft	20-CI-60		0 - 100 °C	Thermowell	City	Contractor		I-104	WX-H0122	
0085	2	5100	FI/FS-X5100	Flow Indicator and Flow Switch	Sulphuric Acid Injection Point 1	Yokogawa	RAG	120 VAC	0.2 - 40 ml/min		City	Contractor	Sulphuric Acid 93%	I-120	WX-P0001	
0086	2	5101	FI/FS-X5101	Flow Indicator and Flow Switch	Sulphuric Acid Injection Point 2	Yokogawa	RAG	120 VAC	0.2 - 40 ml/min		City	Contractor	Sulphuric Acid 93%	I-120	WX-P0001	
0087	2	5110	FI/FS-X5110	Flow Indicator and Flow Switch	Ferric Chloride Injection Point 1	Yokogawa	RAG	120 VAC	1.8 - 100 ml/min		City	Contractor	Ferric Chloride 39%	I-120	WX-P0001	
0088	2	5111	FI/FS-X5111	Flow Indicator and Flow Switch	Ferric Chloride Injection Point 2	Yokogawa	RAG	120 VAC	1.8 - 100 ml/min		City	Contractor	Ferric Chloride 39%	I-120	WX-P0001	
0089	2	5120	FI/FS-X5120	Flow Indicator and Flow Switch	Caustic Soda Injection Point 1	Yokogawa	RAG	120 VAC	1 - 12 ml/min		City	Contractor	Caustic Soda 25%	I-120	WX-P0002	
0090	2	5121	FI/FS-X5121	Flow Indicator and Flow Switch	Caustic Soda Injection Point 2	Yokogawa	RAG	120 VAC	1 - 12 ml/min		City	Contractor	Caustic Soda 25%	I-120	WX-P0002	
0091	2	5122	FI/FS-X5122	Flow Indicator and Flow Switch	Caustic Soda Injection Point 3	Yokogawa	RAG	120 VAC	1 - 12 ml/min		City	Contractor	Caustic Soda 25%	I-120	WX-P0004	
0092	2	5123	FI/FS-X5123	Flow Indicator and Flow Switch	Caustic Soda Injection Point 4	Yokogawa	RAG	120 VAC	1 - 12 ml/min		City	Contractor	Caustic Soda 25%	I-120	WX-P0006	
0076	2	6060	FS-X6060	Flow Switch	Emergency Shower	Magnetrol	TEM-A210-001				Contractor	Contractor		I-117	WX-H0122	WX-E0121

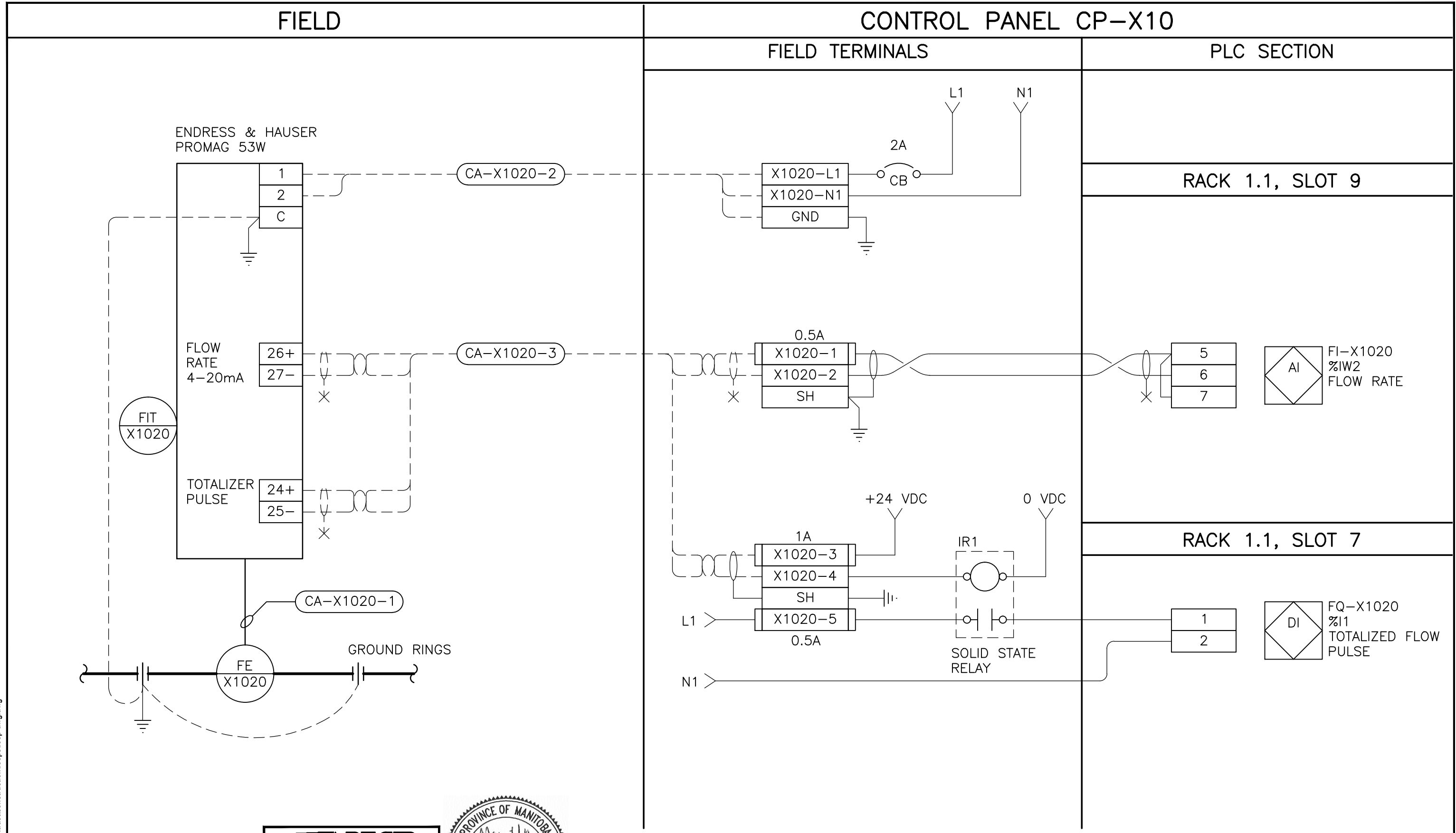

File Name: g:\cad\127079\contract\construction\loops\loop-dwg.dwg

APEGM
 Certificate of Authorization
 Dillon Consulting Limited (MB)
 No. 1789 Date: 2014-05-01

PROVINCE OF MANITOBA
 May 11/14
 B.L. MOORE
 REGISTERED PROFESSIONAL ENGINEER

CH2MHILL.

DILLON
 CONSULTING

DATE 2014-04-28

PROJECT
 CITY OF WINNIPEG WATER TREATMENT RESEARCH
 AND PROCESS OPTIMIZATION FACILITY

TITLE
INSTRUMENTATION
FE/FIT-X1020 LOOP DIAGRAM

PROJECT NO.
127079

FIGURE NO.
1

FIELD

CONTROL PANEL CP-X10

FIELD TERMINALS

PLC SECTION

RACK 1.1, SLOT 10

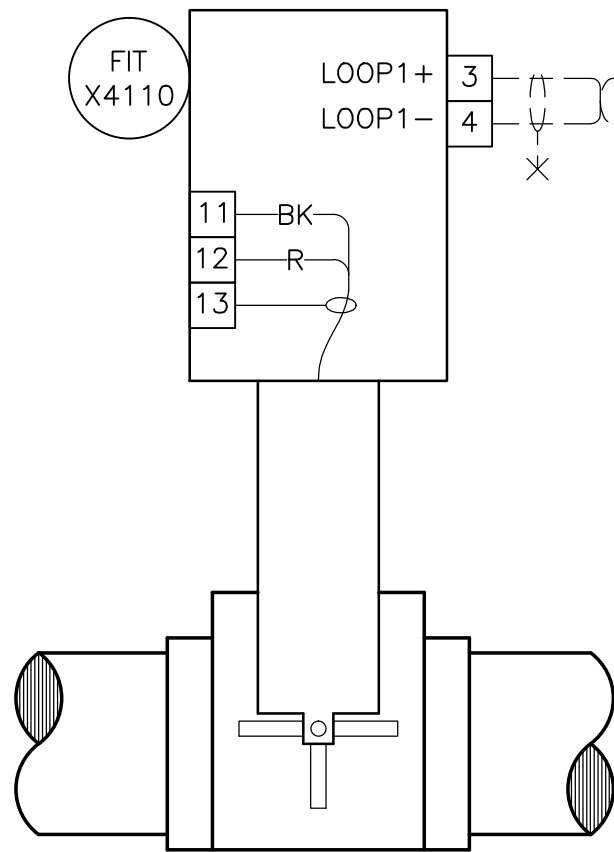

CA-X4110-1

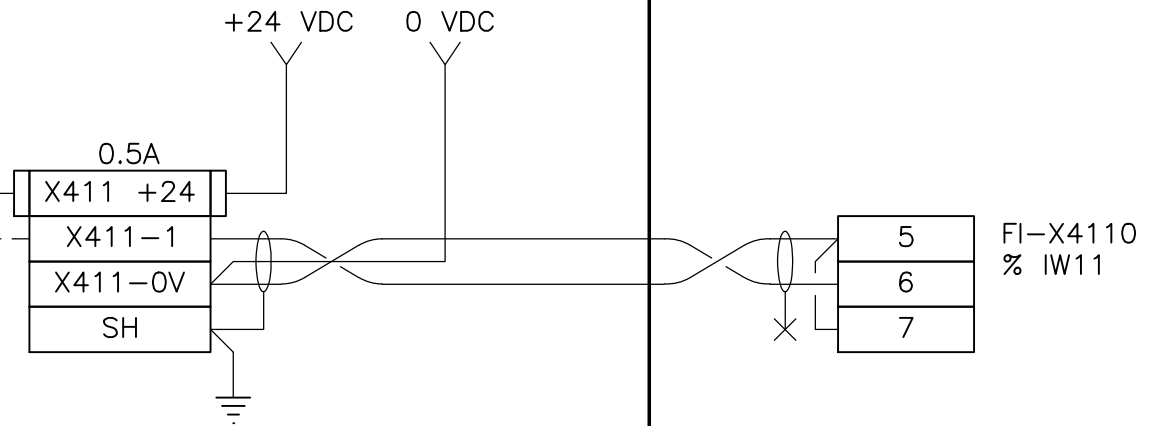

APEGM
 Certificate of Authorization
 Dillon Consulting Limited (MB)
 No. 1789 Date: 2014-05-01

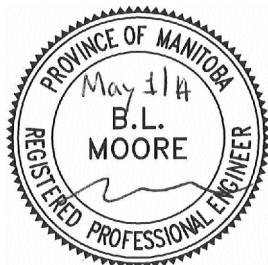

CH2MHILL.



DATE 2014-04-28

PROJECT
 CITY OF WINNIPEG WATER TREATMENT RESEARCH
 AND PROCESS OPTIMIZATION FACILITY

TITLE
**INSTRUMENTATION
 FIT-X4110 LOOP DIAGRAM**

PROJECT NO.
127079

FIGURE NO.
2

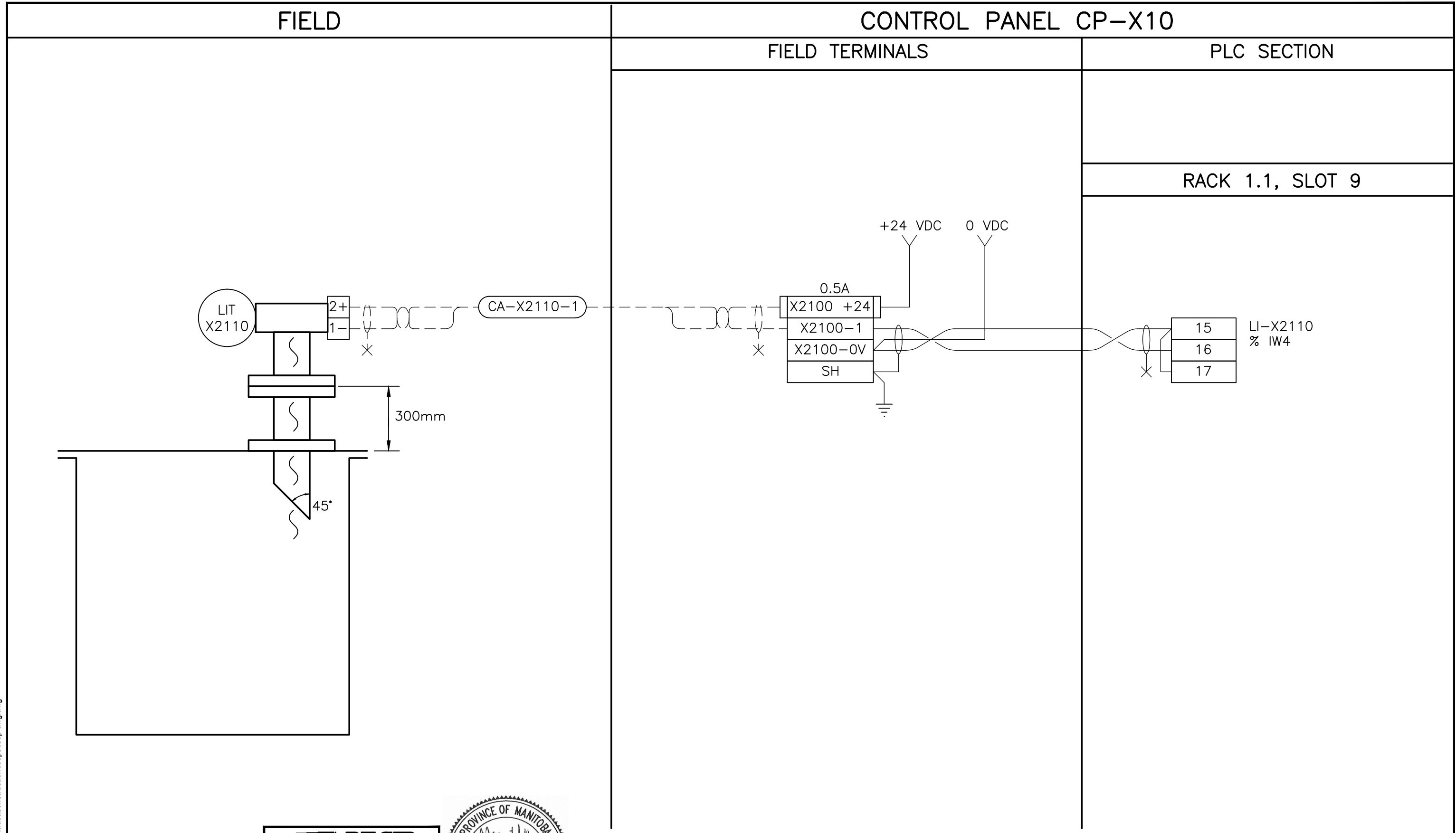

File Name: g:\cad\127079\contract\construction\loops\loop-dwg.dwg

APEGM
 Certificate of Authorization
 Dillon Consulting Limited (MB)
 No. 1789 Date: 2014-05-01

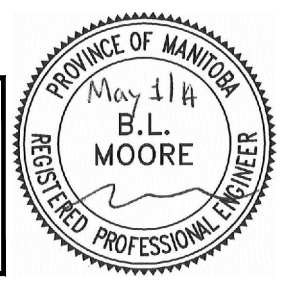

CH2MHILL.

DILLON CONSULTING
 DATE 2014-04-28

PROJECT
 CITY OF WINNIPEG WATER TREATMENT RESEARCH
 AND PROCESS OPTIMIZATION FACILITY
 TITLE
INSTRUMENTATION
LE/LIT-X2100 LOOP DIAGRAM

PROJECT NO.
127079
 FIGURE NO.
3

FIELD

CONTROL PANEL CP-X10

FIELD TERMINALS

PLC SECTION

RACK 1.1, SLOT 7

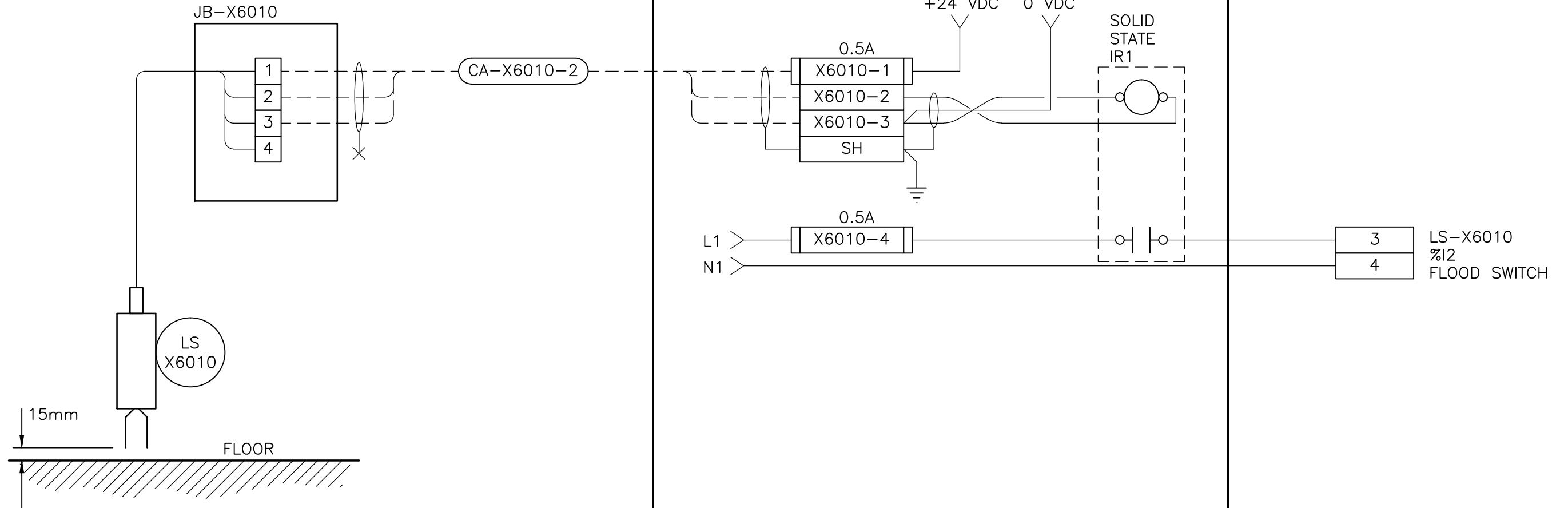

APEGM
 Certificate of Authorization
 Dillon Consulting Limited (MB)
 No. 1789 Date: 2014-05-01

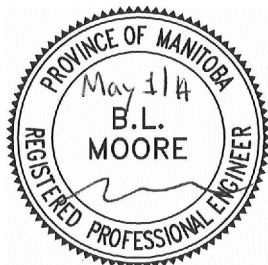

CH2MHILL.



DATE 2014-04-28

PROJECT
 CITY OF WINNIPEG WATER TREATMENT RESEARCH
 AND PROCESS OPTIMIZATION FACILITY

TITLE
**INSTRUMENTATION
 LS-X6010 LOOP DIAGRAM**

PROJECT NO.
127079

FIGURE NO.
4

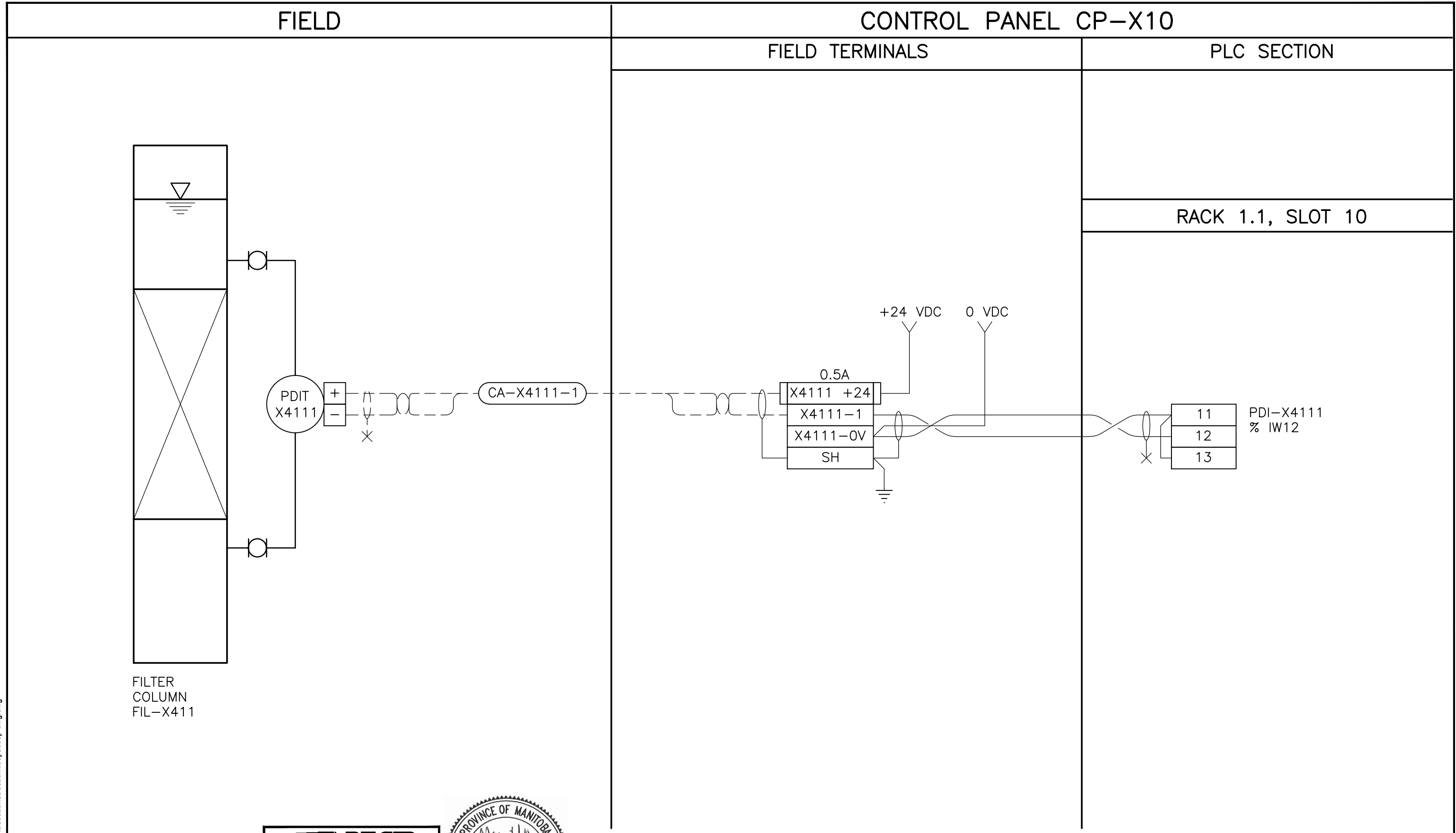

FILTER
COLUMN
FIL-X411

APEGM
Certificate of Authorization
Dillon Consulting Limited (MB)
No. 1789 Date: 2014-05-01



CH2MHILL.



DATE 2014-04-28

PROJECT
CITY OF WINNIPEG WATER TREATMENT RESEARCH
AND PROCESS OPTIMIZATION FACILITY

TITLE
**INSTRUMENTATION
PDIT-X4111 LOOP DIAGRAM**

PROJECT NO.
127079

FIGURE NO.
5

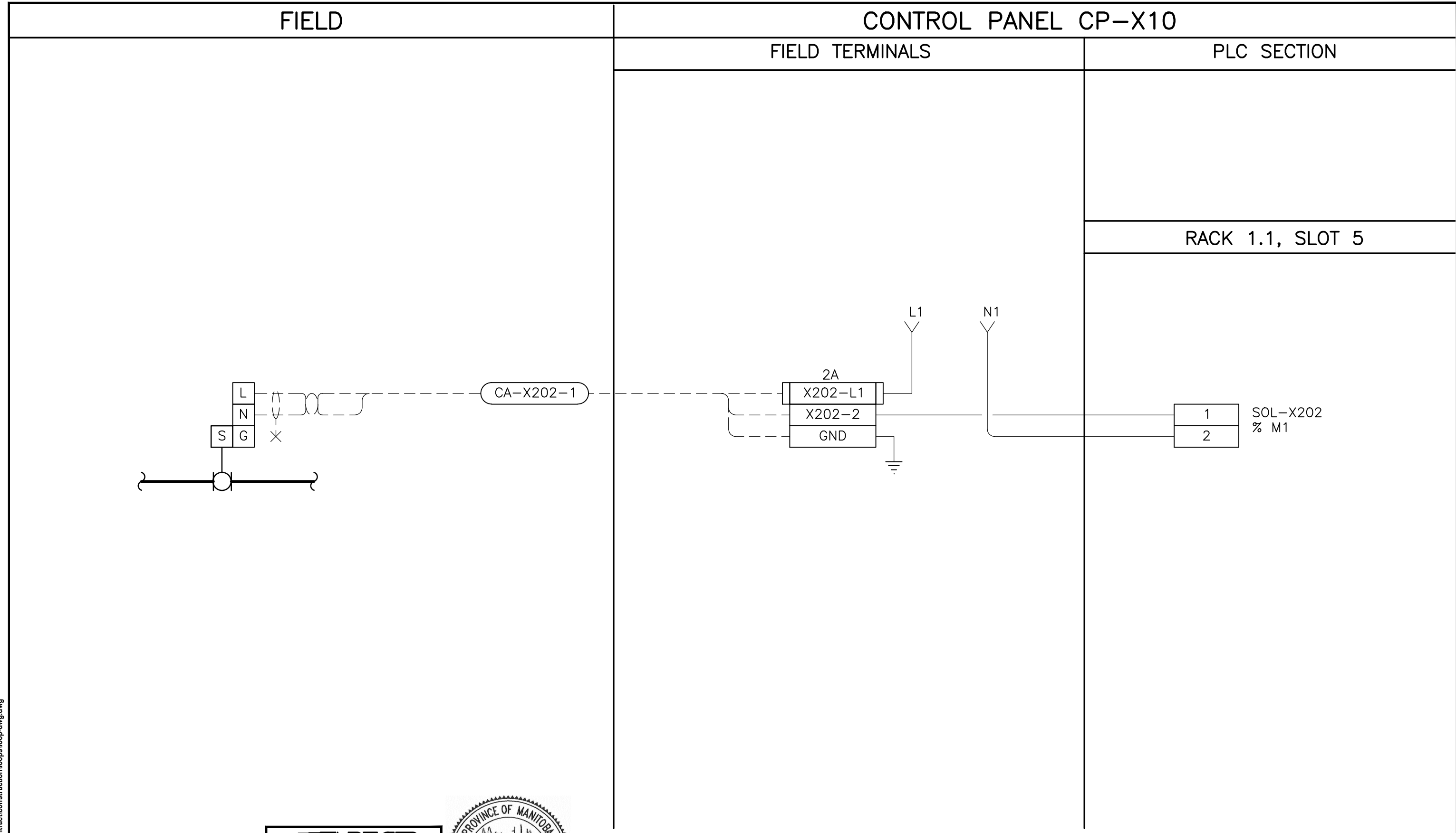

APEGM
 Certificate of Authorization
 Dillon Consulting Limited (MB)
 No. 1789 Date: 2014-05-01



CH2MHILL.



DATE 2014-04-28

PROJECT
 CITY OF WINNIPEG WATER TREATMENT RESEARCH
 AND PROCESS OPTIMIZATION FACILITY

TITLE
**INSTRUMENTATION
 SOL-X202 LOOP DIAGRAM**

PROJECT NO.
127079

FIGURE NO.
6

FIELD

CONTROL PANEL CP-X10

ENDRESS & HAUSER
CPM253

FIELD TERMINALS

PLC SECTION

pH
AIT
X1022

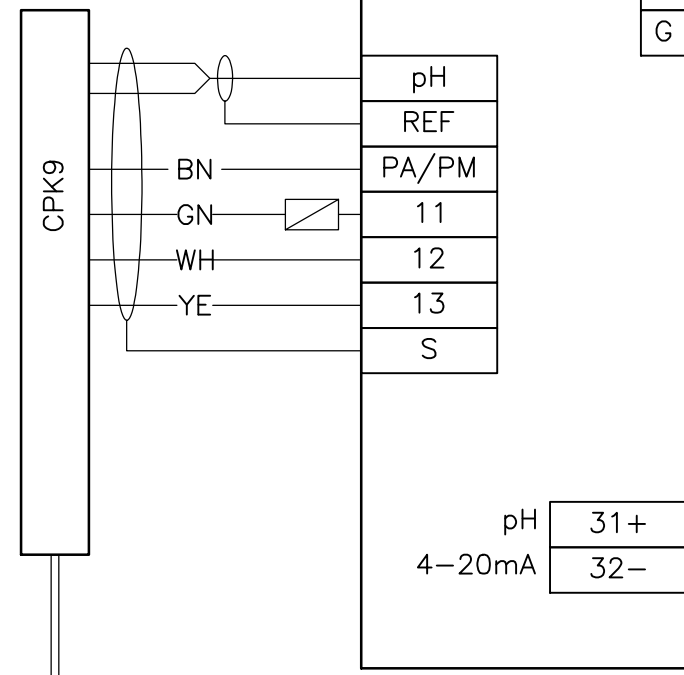

L+
N-
G

CA-X1022-2

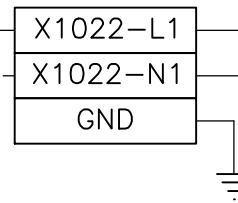

RACK 1.1, SLOT 9

pH
4-20mA
31+
32-

CA-X1022-3

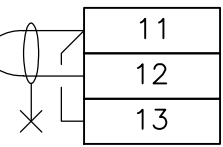
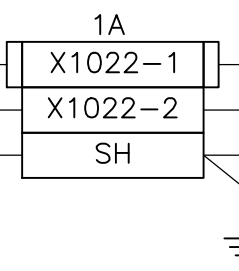

AI
AI-X1022.pH
%IW3

AE
X1022
CPS11

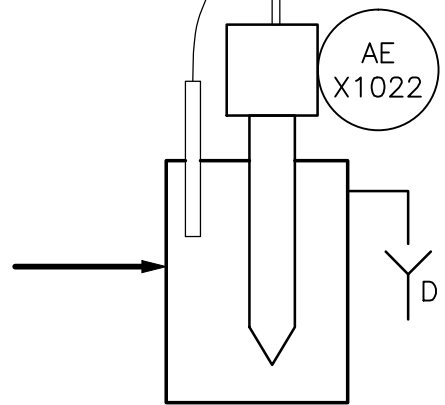

APEGM
Certificate of Authorization
Dillon Consulting Limited (MB)
No. 1789 Date: 2014-05-01

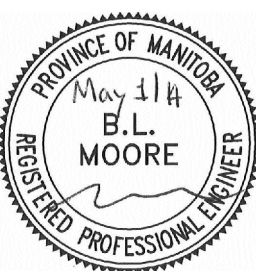

CH2MHILL.



DATE 2014-04-28

PROJECT
CITY OF WINNIPEG WATER TREATMENT RESEARCH
AND PROCESS OPTIMIZATION FACILITY

TITLE
**INSTRUMENTATION
AE/AIT-X1022 LOOP DIAGRAM**

PROJECT NO.
127079

FIGURE NO.
7

FIELD

CONTROL PANEL CP-X10

FIELD TERMINALS

PLC SECTION

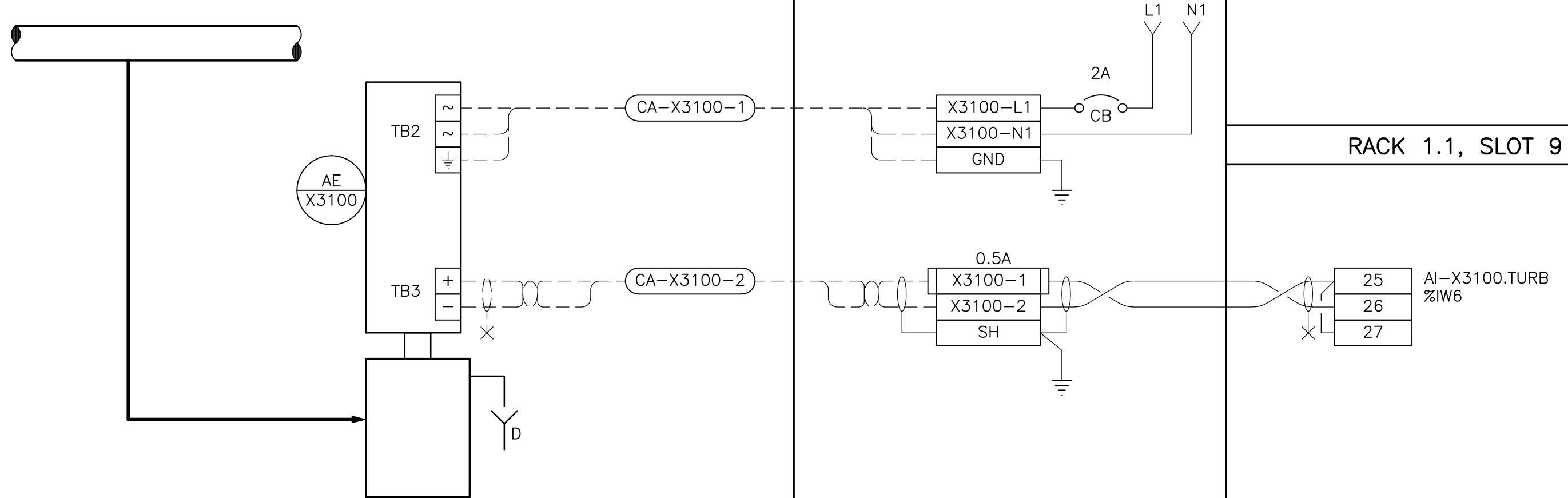

APEGM
 Certificate of Authorization
 Dillon Consulting Limited (MB)
 No. 1789 Date: 2014-05-01

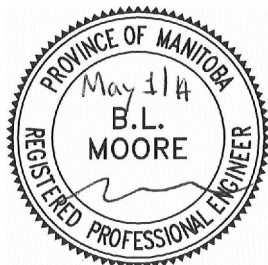

CH2MHILL.



DATE 2014-04-28

PROJECT
 CITY OF WINNIPEG WATER TREATMENT RESEARCH
 AND PROCESS OPTIMIZATION FACILITY

TITLE
**INSTRUMENTATION
 AE/AIT-X3100 LOOP DIAGRAM**

PROJECT NO.
127079

FIGURE NO.
8

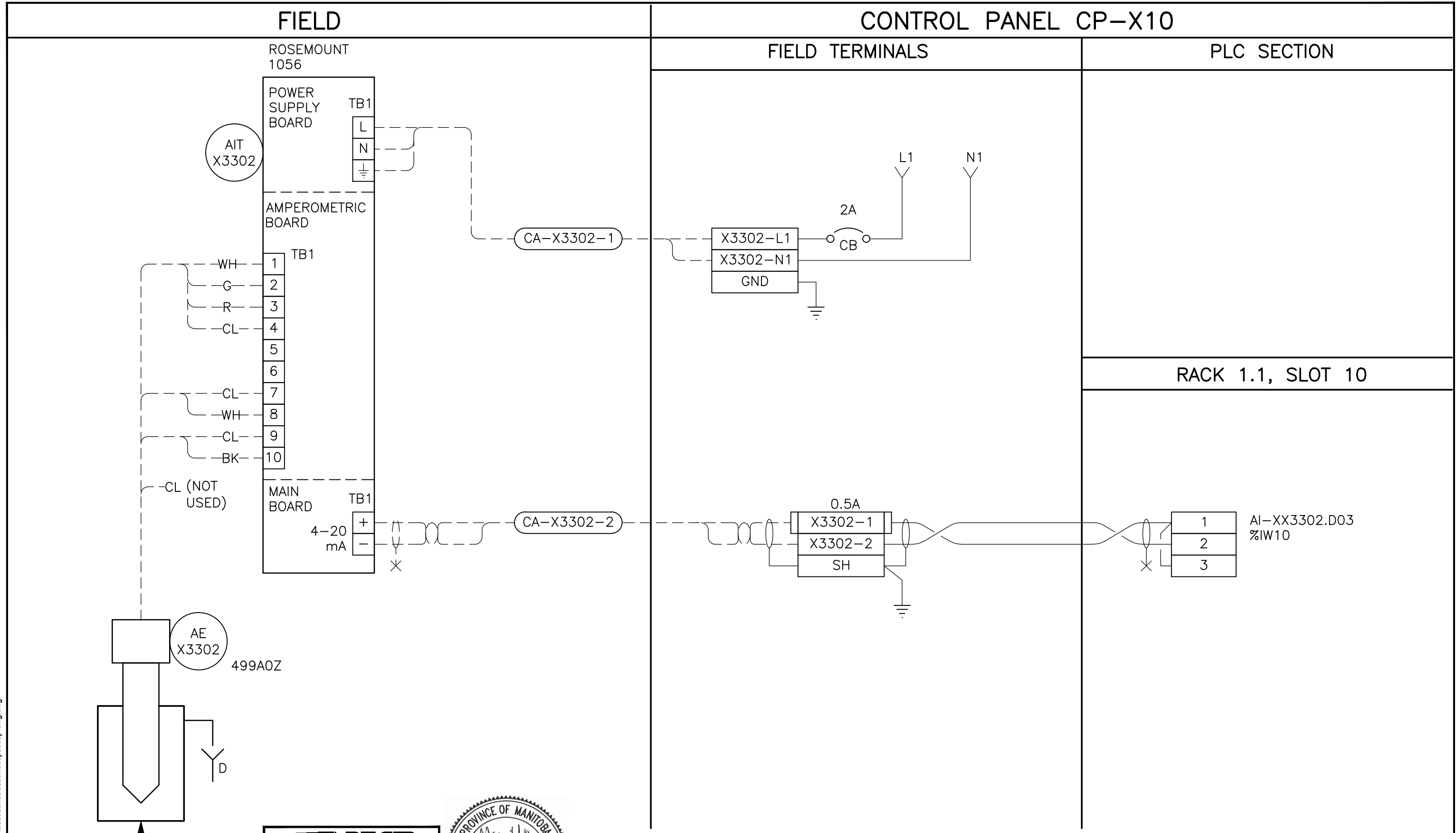

File Name: g:\cad\127079\contract\construction\loops\loop-dwg.dwg

APEGM
Certificate of Authorization
Dillon Consulting Limited (MB)
No. 1789 Date: 2014-05-01

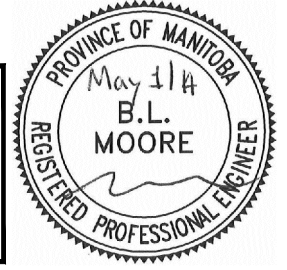

CH2MHILL.

DILLON CONSULTING
DATE 2014-04-28

PROJECT
CITY OF WINNIPEG WATER TREATMENT RESEARCH
AND PROCESS OPTIMIZATION FACILITY
TITLE
**INSTRUMENTATION
AIT-X3302 LOOP DIAGRAM**

PROJECT NO.
127079
FIGURE NO.
9

FIELD

CONTROL PANEL CP-H10B

NEAREST 120 VAC PANEL
BOARD 15A, CCT. No. _____

CA-CP-H10B-1

FIELD TERMINALS

PLC SECTION

RACK 2.1, SLOT 5

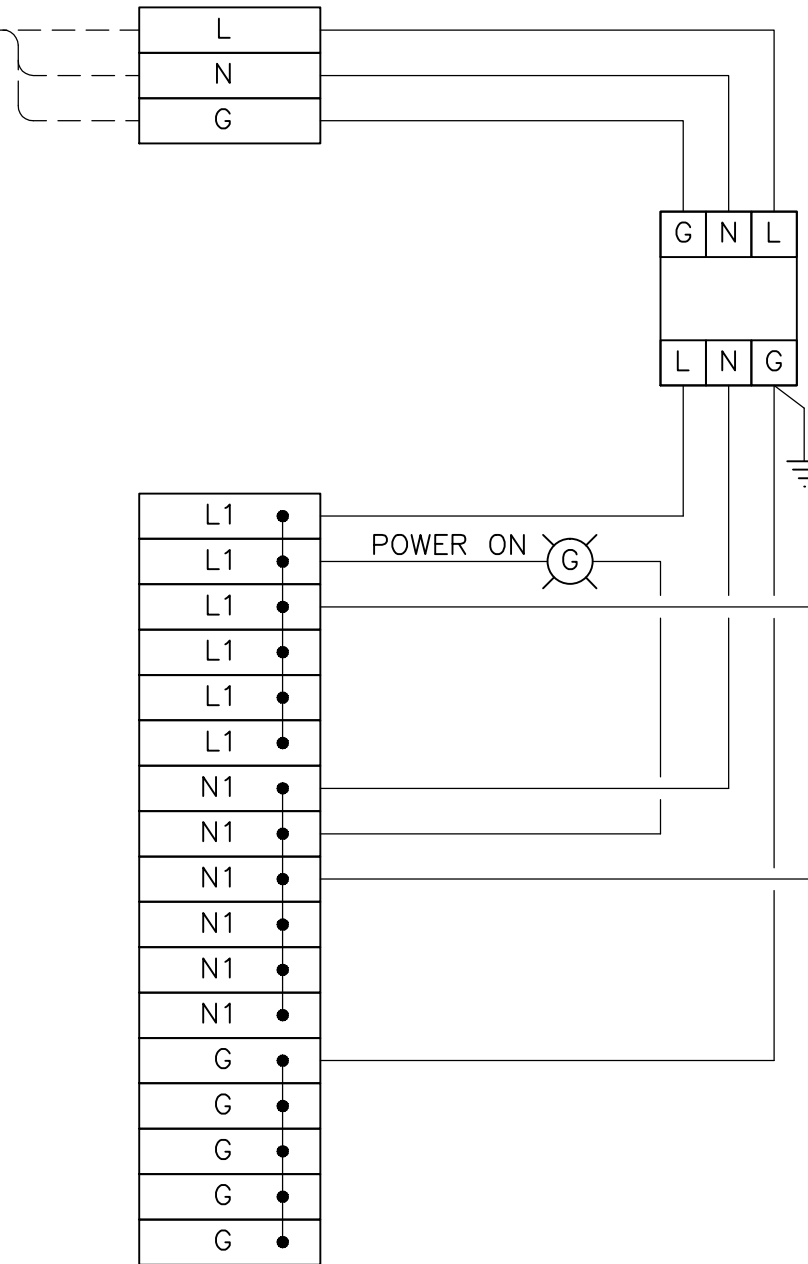

APEGM
Certificate of Authorization
Dillon Consulting Limited (MB)
No. 1789 Date: 2014-05-01

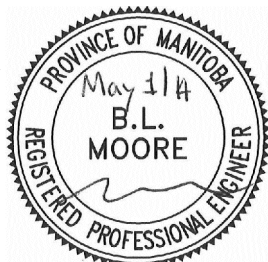

CH2MHILL.



DATE 2014-04-28

PROJECT CITY OF WINNIPEG WATER TREATMENT RESEARCH AND PROCESS OPTIMIZATION FACILITY

TITLE INSTRUMENTATION CP-H10B NORMAL POWER SUPPLY

PROJECT NO. 127079

FIGURE NO. 10

FIELD

CONTROL PANEL CP-H10B

FIELD TERMINALS

PLC SECTION

RACK 2.1, SLOT 5

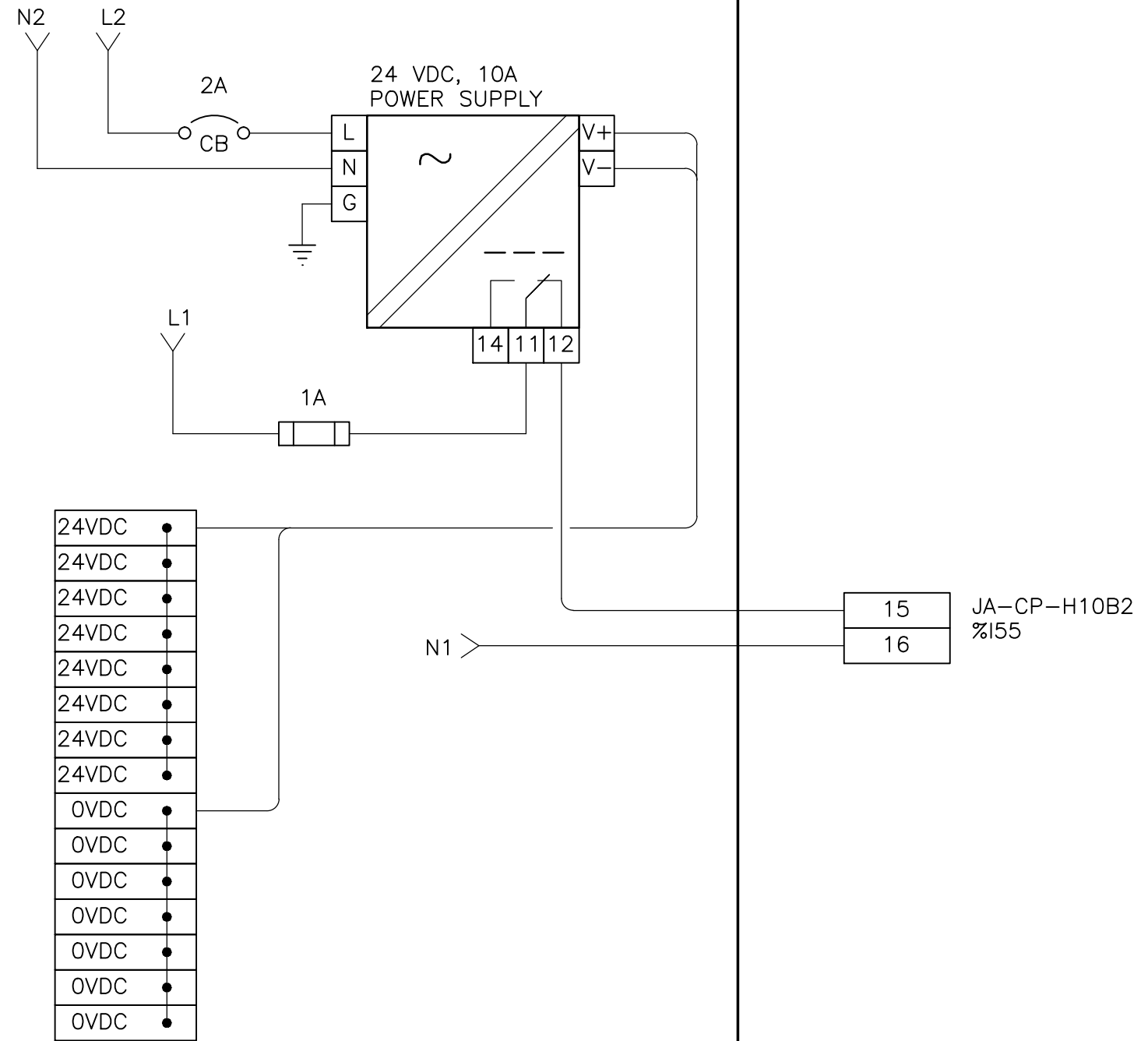

APEGM
 Certificate of Authorization
 Dillon Consulting Limited (MB)
 No. 1789 Date: 2014-05-01

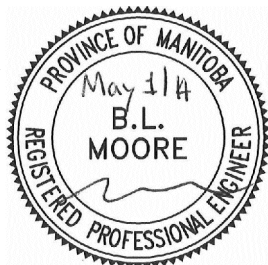

CH2MHILL.



DATE 2014-04-28

PROJECT CITY OF WINNIPEG WATER TREATMENT RESEARCH AND PROCESS OPTIMIZATION FACILITY

TITLE INSTRUMENTATION CP-H10B 24 VDC POWER SUPPLY

PROJECT NO. 127079

FIGURE NO. 11

FIELD

CONTROL PANEL CP-H10B

FIELD TERMINALS

PLC SECTION

NEAREST UPS
PANEL BOARD
15A CCT No. ____

CA-CP-H10B-2

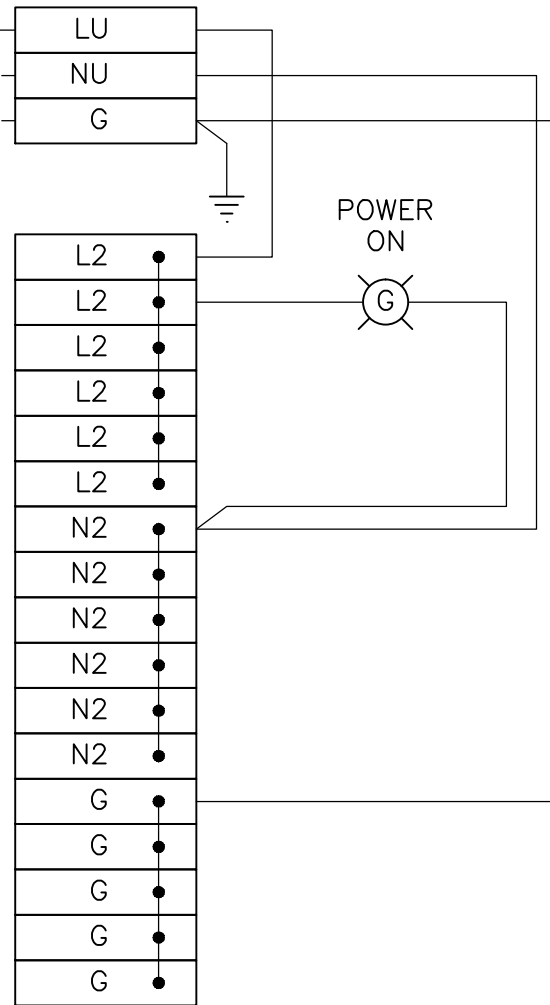

File Name: g:\cad\127079\contract\construction\loops loop-dwg.dwg

APEGM
Certificate of Authorization
Dillon Consulting Limited (MB)
No. 1789 Date: 2014-05-01

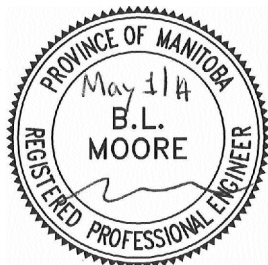

CH2MHILL.



DATE 2014-04-28

PROJECT CITY OF WINNIPEG WATER TREATMENT RESEARCH AND PROCESS OPTIMIZATION FACILITY

TITLE INSTRUMENTATION CP-H10B UPS POWER SUPPLY

PROJECT NO. 127079

FIGURE NO. 12

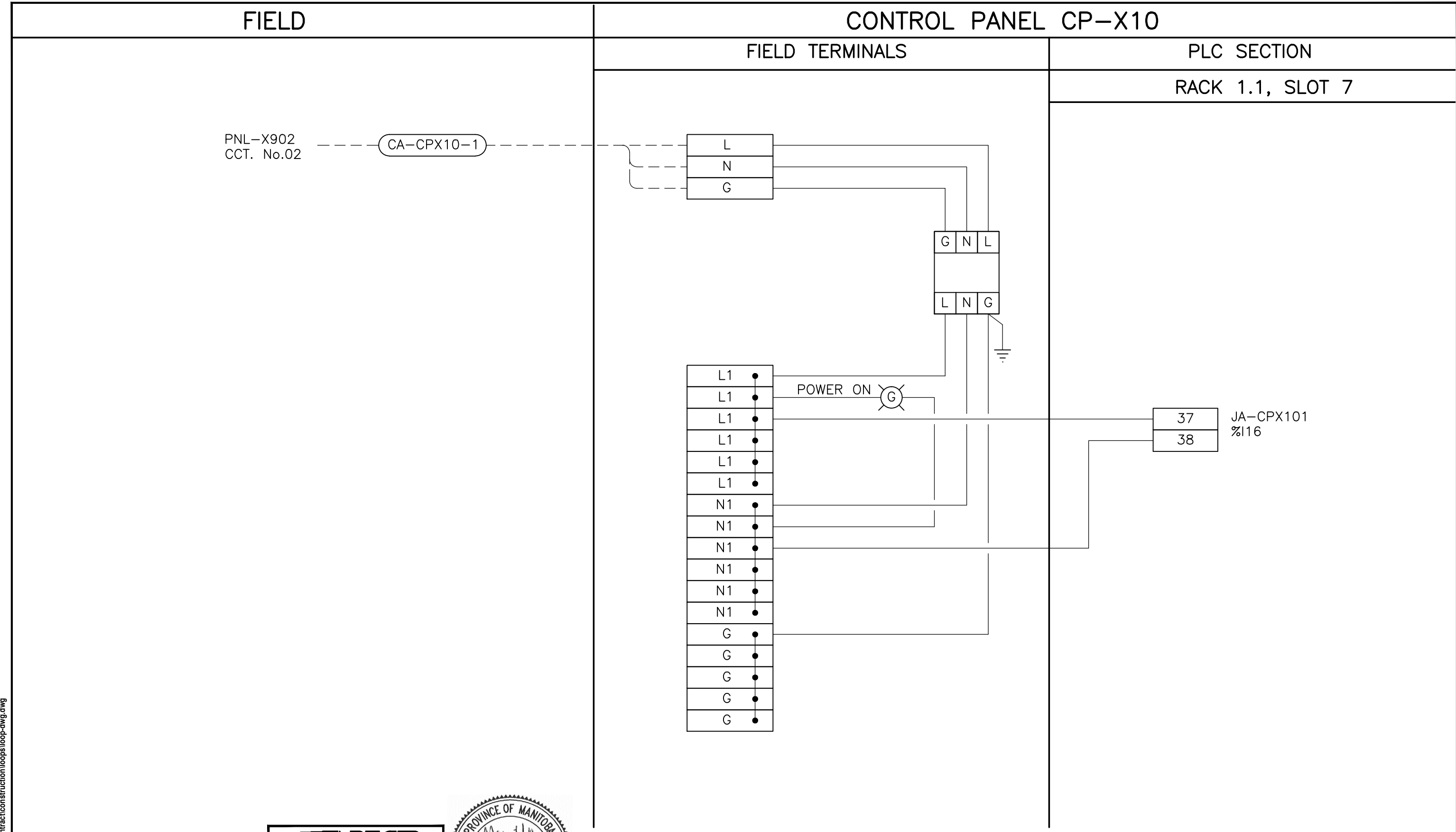

APEGM
 Certificate of Authorization
 Dillon Consulting Limited (MB)
 No. 1789 Date: 2014-05-01

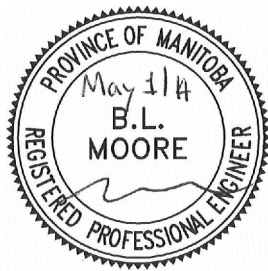

CH2MHILL.



DATE 2014-04-28

PROJECT CITY OF WINNIPEG WATER TREATMENT RESEARCH AND PROCESS OPTIMIZATION FACILITY

TITLE INSTRUMENTATION CP-X10 NORMAL POWER SUPPLY

PROJECT NO. 127079

FIGURE NO. 13

FIELD

CONTROL PANEL CP-X10

FIELD TERMINALS

PLC SECTION

RACK 1.1, SLOT 8

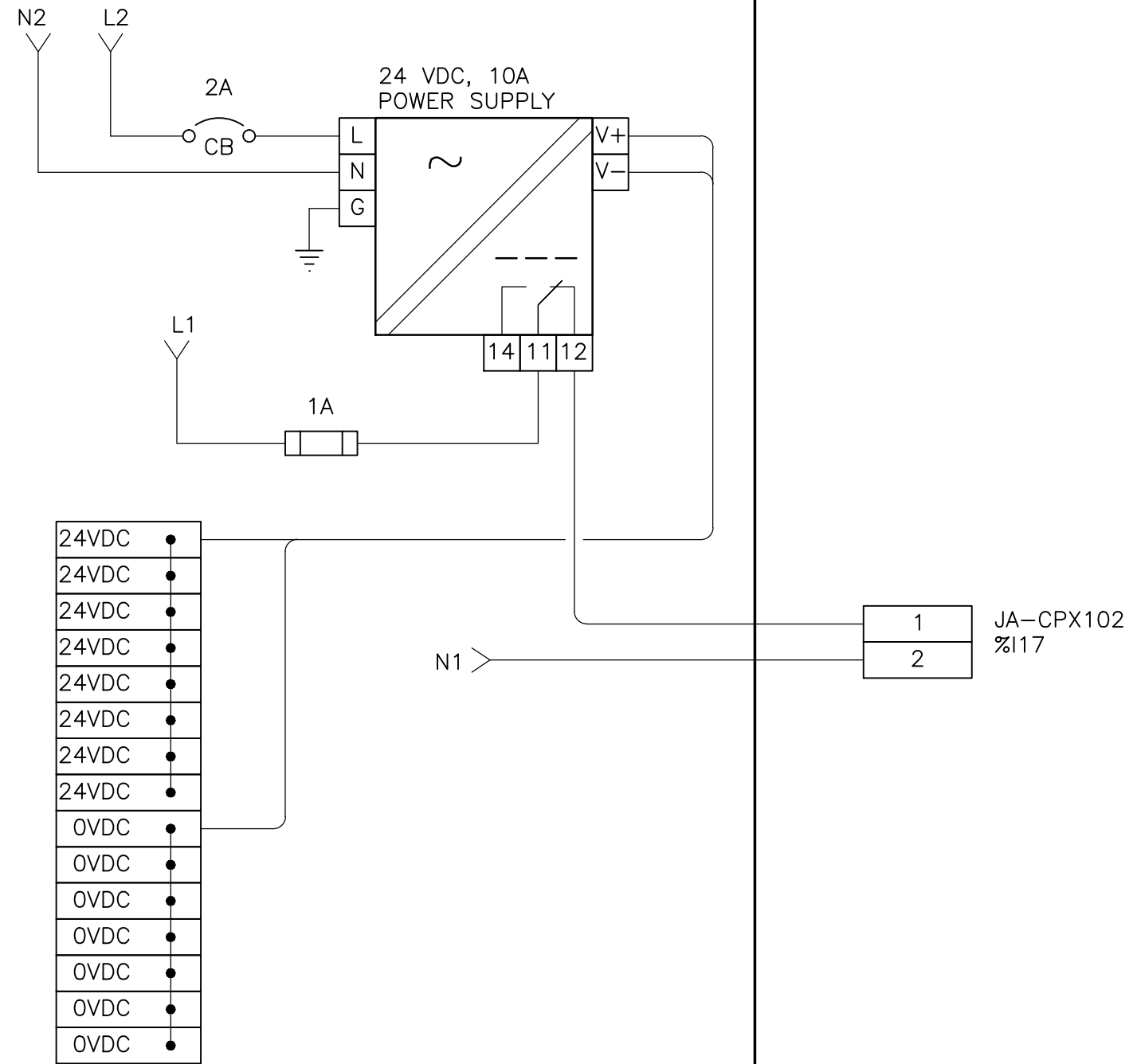

APEGM
Certificate of Authorization
Dillon Consulting Limited (MB)
No. 1789 Date: 2014-05-01

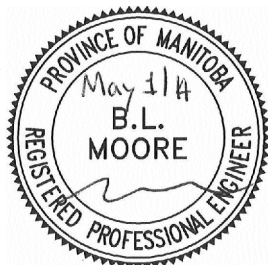

CH2MHILL.



DATE 2014-04-28

PROJECT CITY OF WINNIPEG WATER TREATMENT RESEARCH AND PROCESS OPTIMIZATION FACILITY

TITLE INSTRUMENTATION CP-X10 24 VDC POWER SUPPLY

PROJECT NO. 127079

FIGURE NO. 14

FIELD

CONTROL PANEL CP-X10

NEAREST UPS
PANEL BOARD
15A CCT No. ____

CA-X3302-2

FIELD TERMINALS

PLC SECTION

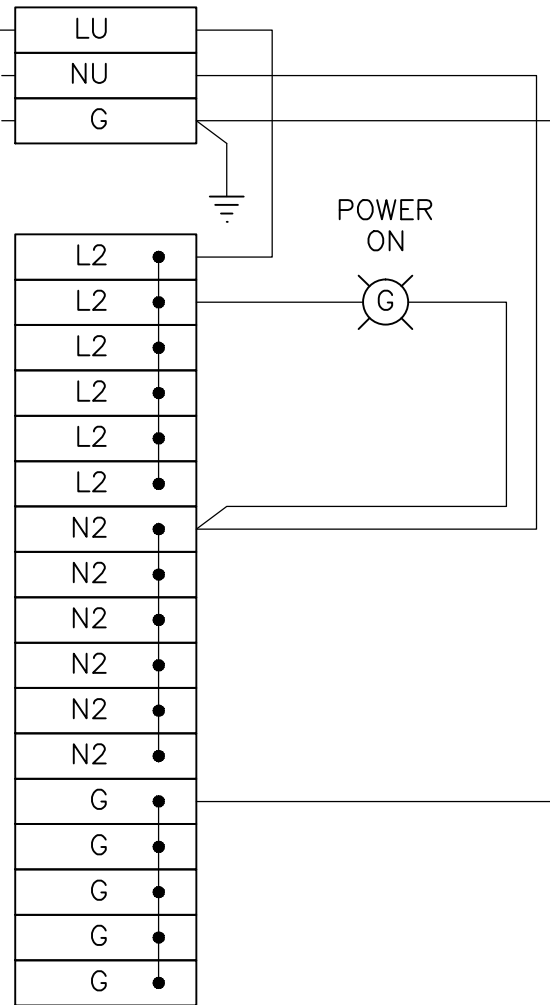

File Name: g:\cad\127079\contract\construction\loops\loop-dwg.dwg

APEGM
Certificate of Authorization
Dillon Consulting Limited (MB)
No. 1789 Date: 2014-05-01

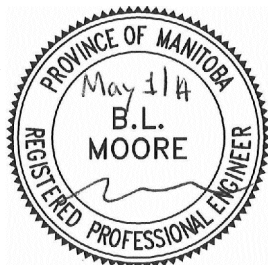

CH2MHILL.



DATE 2014-04-28

PROJECT CITY OF WINNIPEG WATER TREATMENT RESEARCH AND PROCESS OPTIMIZATION FACILITY

TITLE INSTRUMENTATION CP-X10 UPS POWER SUPPLY

PROJECT NO. 127079

FIGURE NO. 15

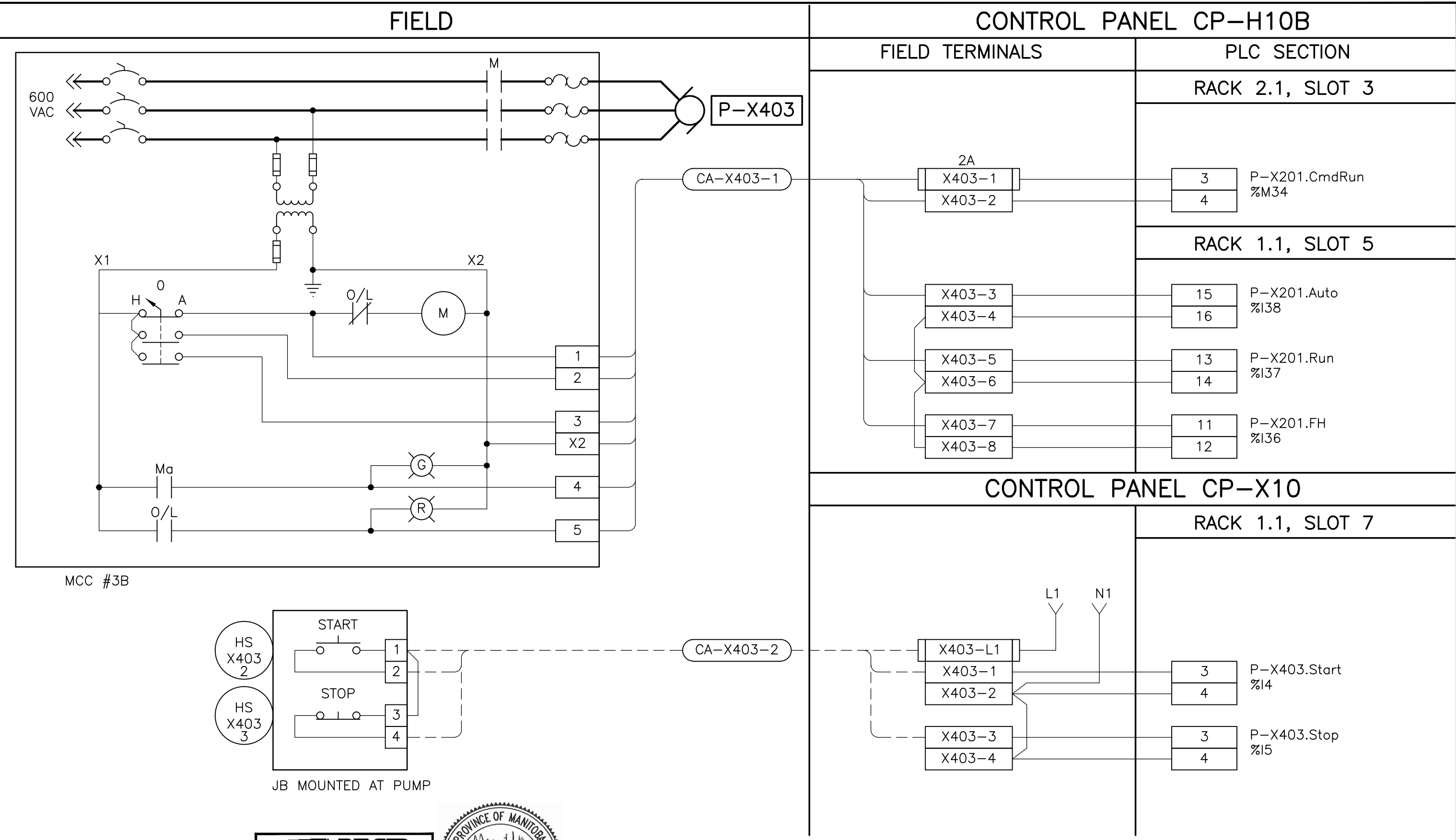

APEGM
 Certificate of Authorization
 Dillon Consulting Limited (MB)
 No. 1789 Date: 2014-05-01



CH2MHILL.



DATE 2014-04-28

PROJECT CITY OF WINNIPEG WATER TREATMENT RESEARCH AND PROCESS OPTIMIZATION FACILITY

TITLE INSTRUMENTATION P-X403 LOOP DIAGRAM

PROJECT NO. 127079

FIGURE NO. 16

FIELD

CONTROL PANEL CP-H10B

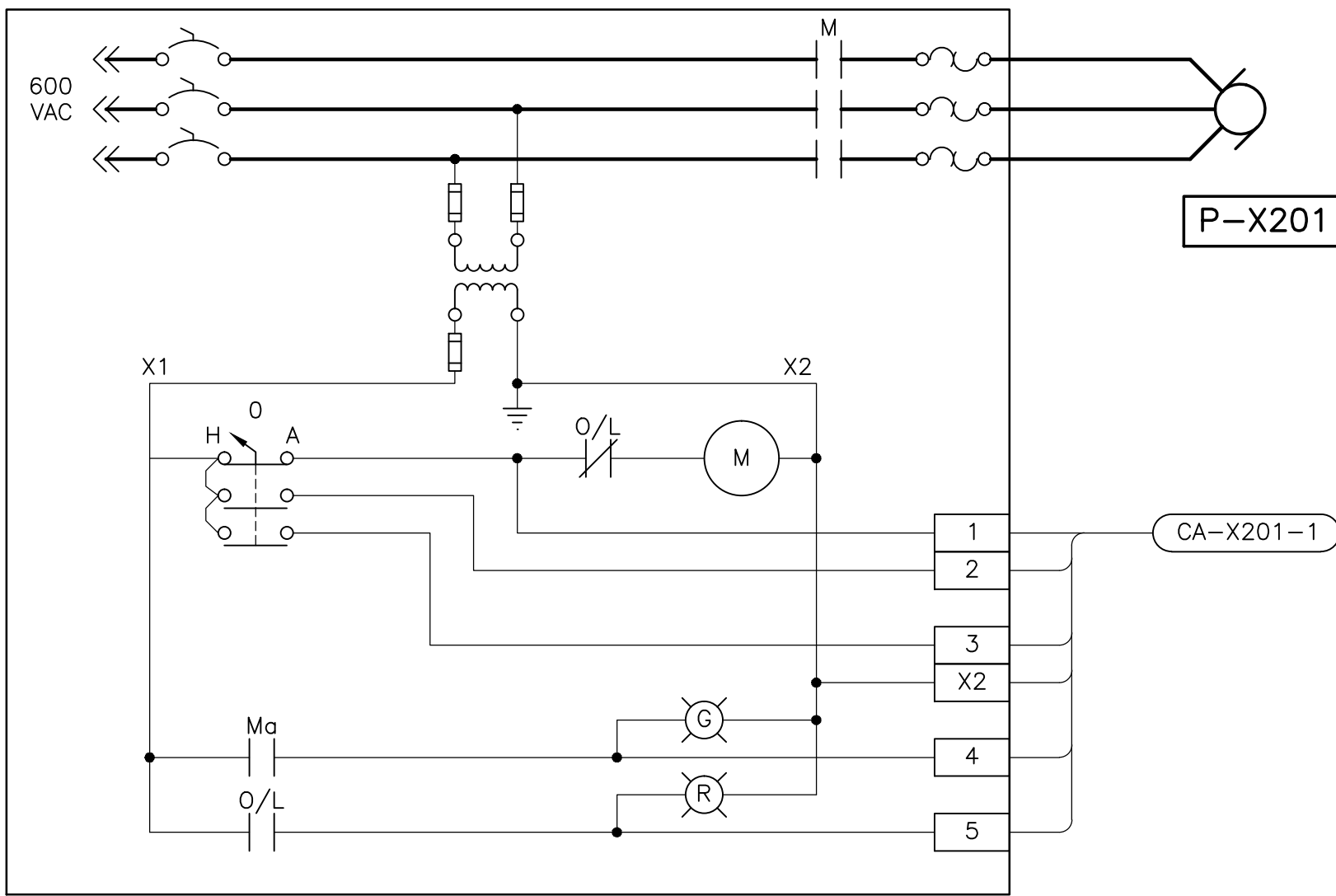

MCC #3B

P-X201

CA-X201-1

FIELD TERMINALS

PLC SECTION

RACK 2.1, SLOT 3

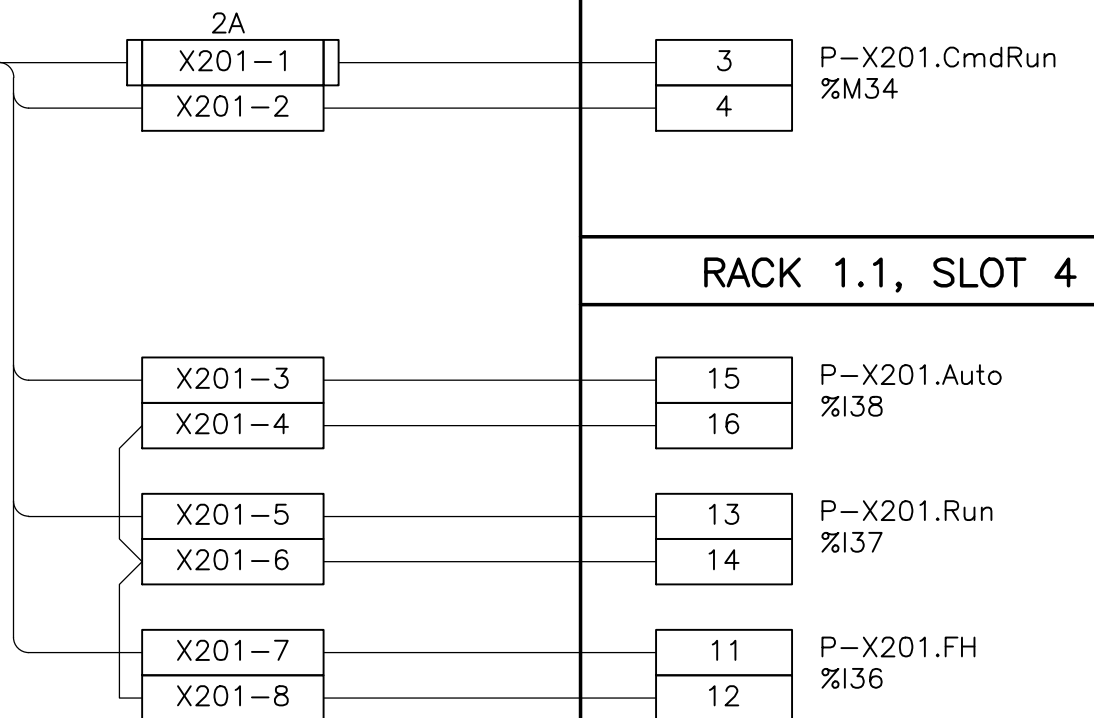

APEGM
 Certificate of Authorization
 Dillon Consulting Limited (MB)
 No. 1789 Date: 2014-05-01

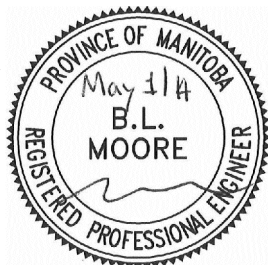

CH2MHILL.



DATE 2014-04-28

PROJECT CITY OF WINNIPEG WATER TREATMENT RESEARCH AND PROCESS OPTIMIZATION FACILITY

TITLE INSTRUMENTATION P-X201 LOOP DIAGRAM

PROJECT NO. 127079

FIGURE NO. 17

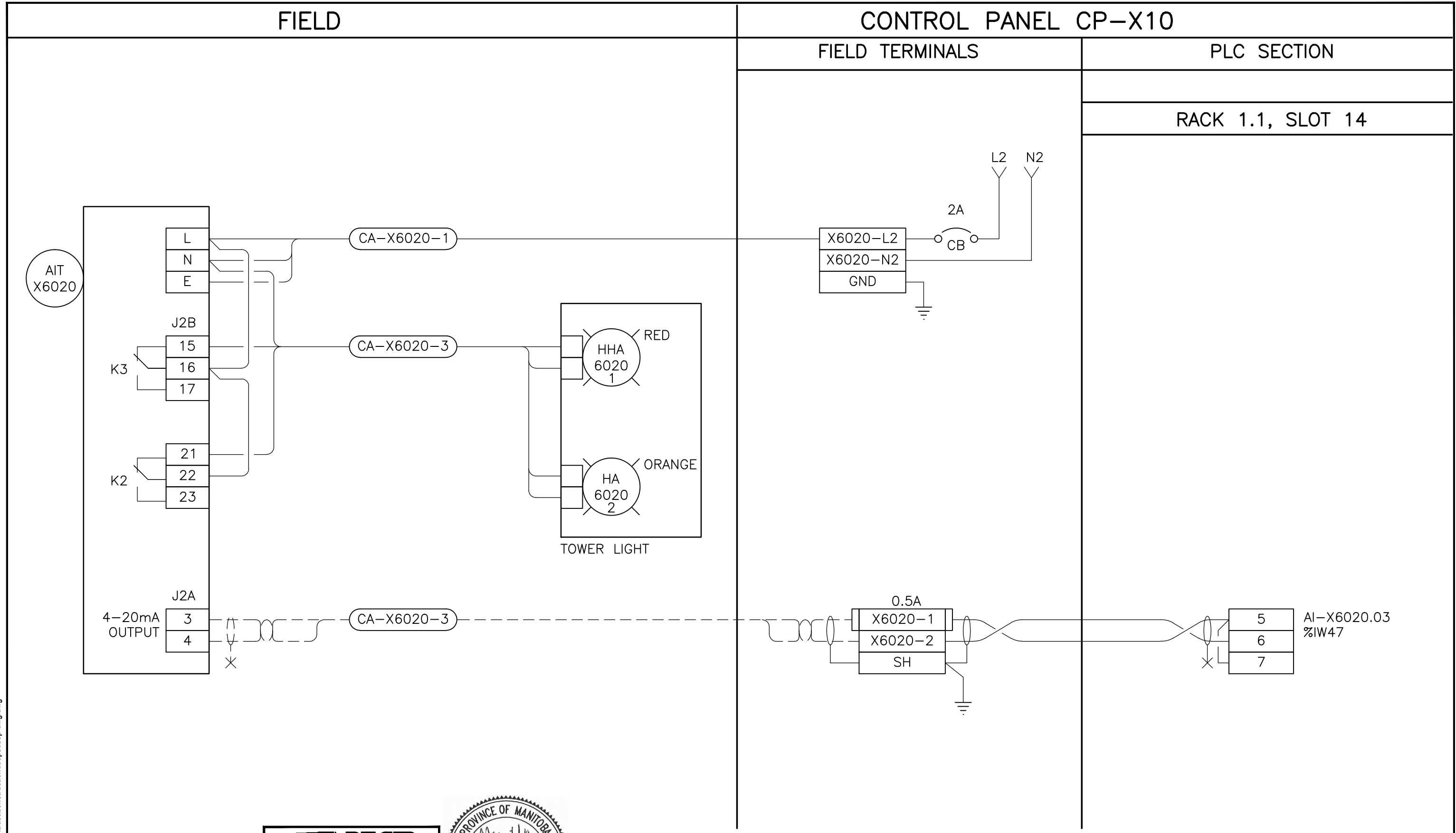

File Name: g:\cad\1127079\contract\construction\loops\loop-dwg.dwg

APEGM
 Certificate of Authorization
 Dillon Consulting Limited (MB)
 No. 1789 Date: 2014-05-01

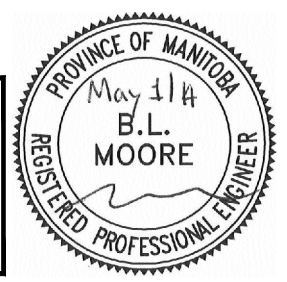

CH2MHILL.



DATE 2014-04-28

PROJECT
 CITY OF WINNIPEG WATER TREATMENT RESEARCH
 AND PROCESS OPTIMIZATION FACILITY

TITLE
**INSTRUMENTATION
 AIT-X6020 LOOP DIAGRAM**

PROJECT NO.
127079

FIGURE NO.
18

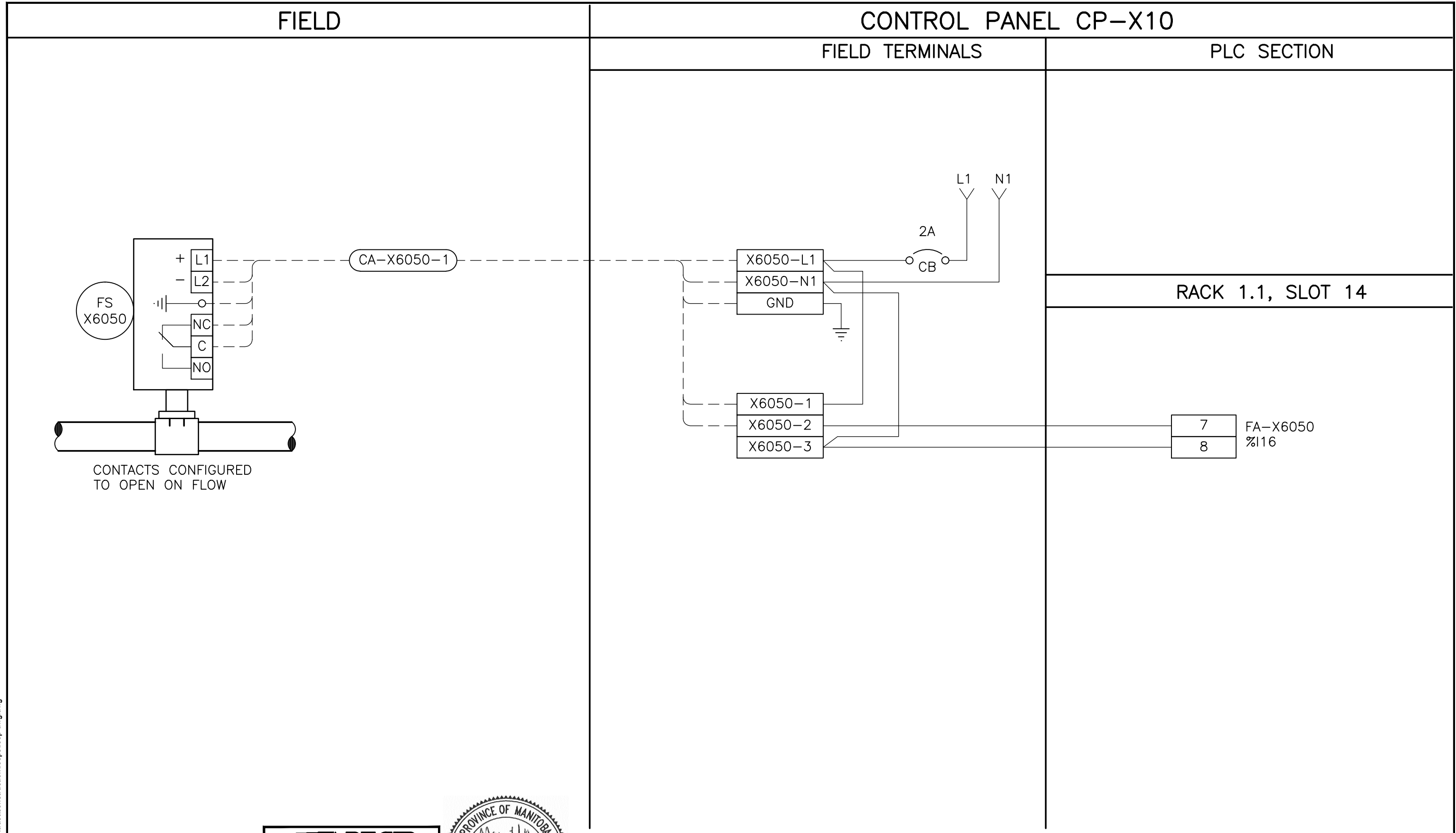

APEGM
 Certificate of Authorization
 Dillon Consulting Limited (MB)
 No. 1789 Date: 2014-05-01

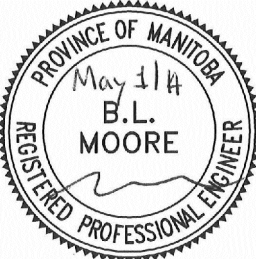

CH2MHILL.

DILLON CONSULTING

DATE 2014-04-28

PROJECT CITY OF WINNIPEG WATER TREATMENT RESEARCH AND PROCESS OPTIMIZATION FACILITY	PROJECT NO. 127079
TITLE INSTRUMENTATION FS-X6050 LOOP DIAGRAM	FIGURE NO. 19

File Name: g:\cad\127079\contract\construction\loops loop-dwg.dwg

FIELD

CONTROL PANEL CP-X10

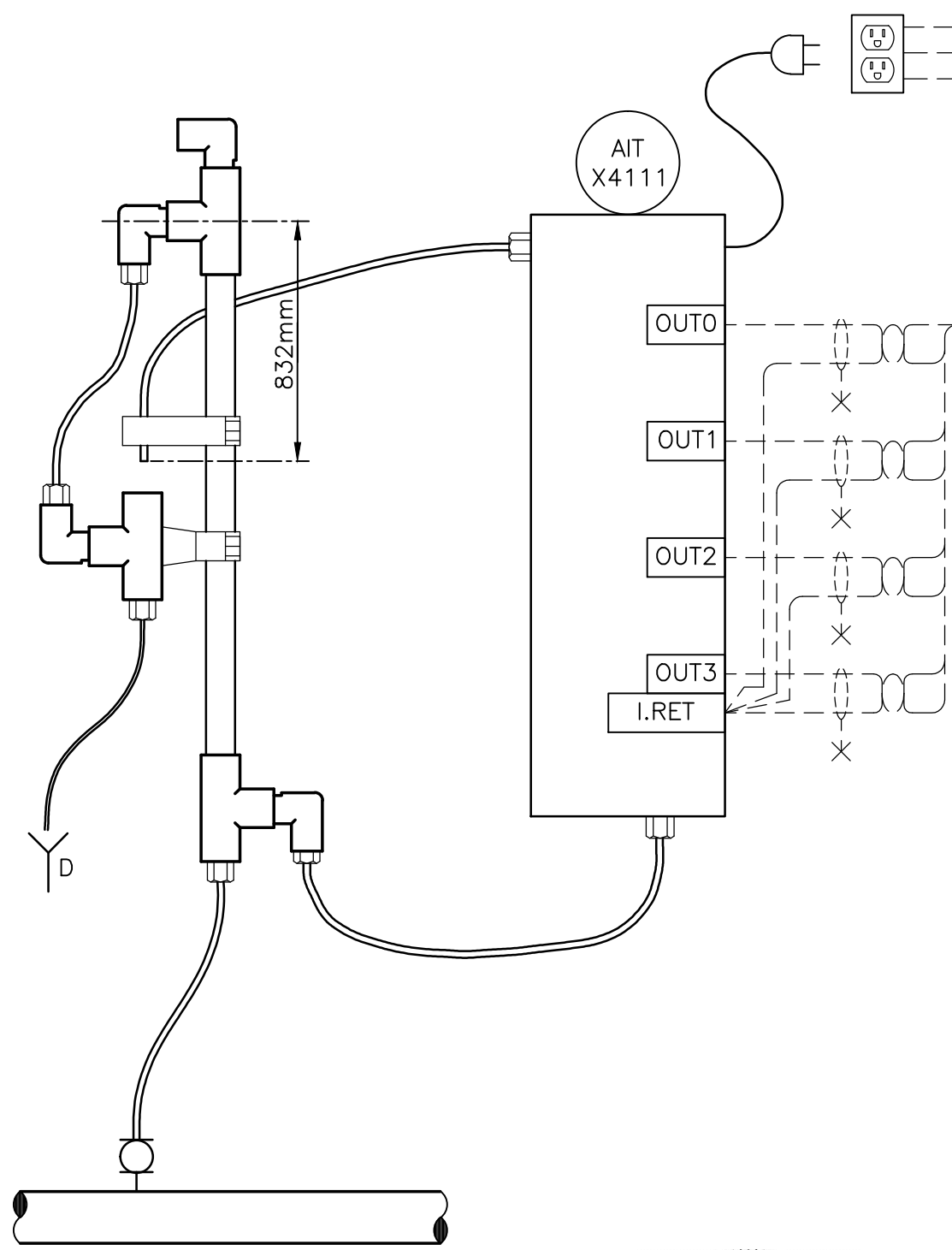

FIELD TERMINALS

PLC SECTION

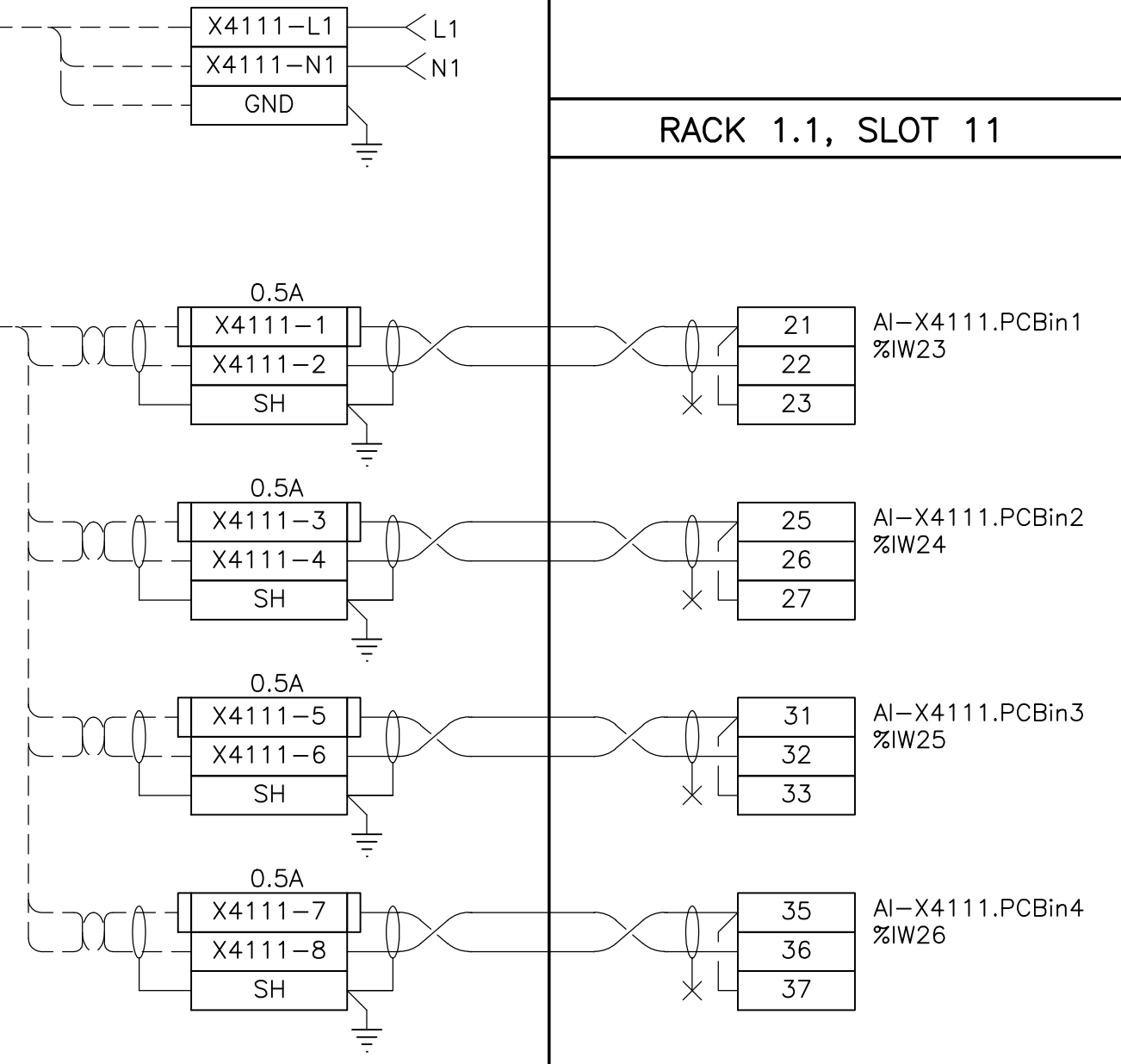

APEGM
 Certificate of Authorization
 Dillon Consulting Limited (MB)
 No. 1789 Date: 2014-05-01

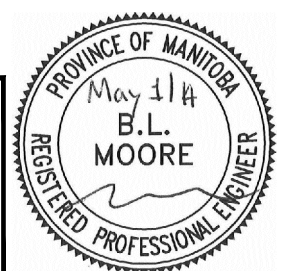

CH2MHILL.



DATE 2014-04-28

PROJECT CITY OF WINNIPEG WATER TREATMENT RESEARCH AND PROCESS OPTIMIZATION FACILITY

TITLE INSTRUMENTATION AIT-X4111 LOOP DIAGRAM

PROJECT NO. 127079

FIGURE NO. 20

File Name: g:\cad\1127079\contract\construction\loops loop-dwg.dwg

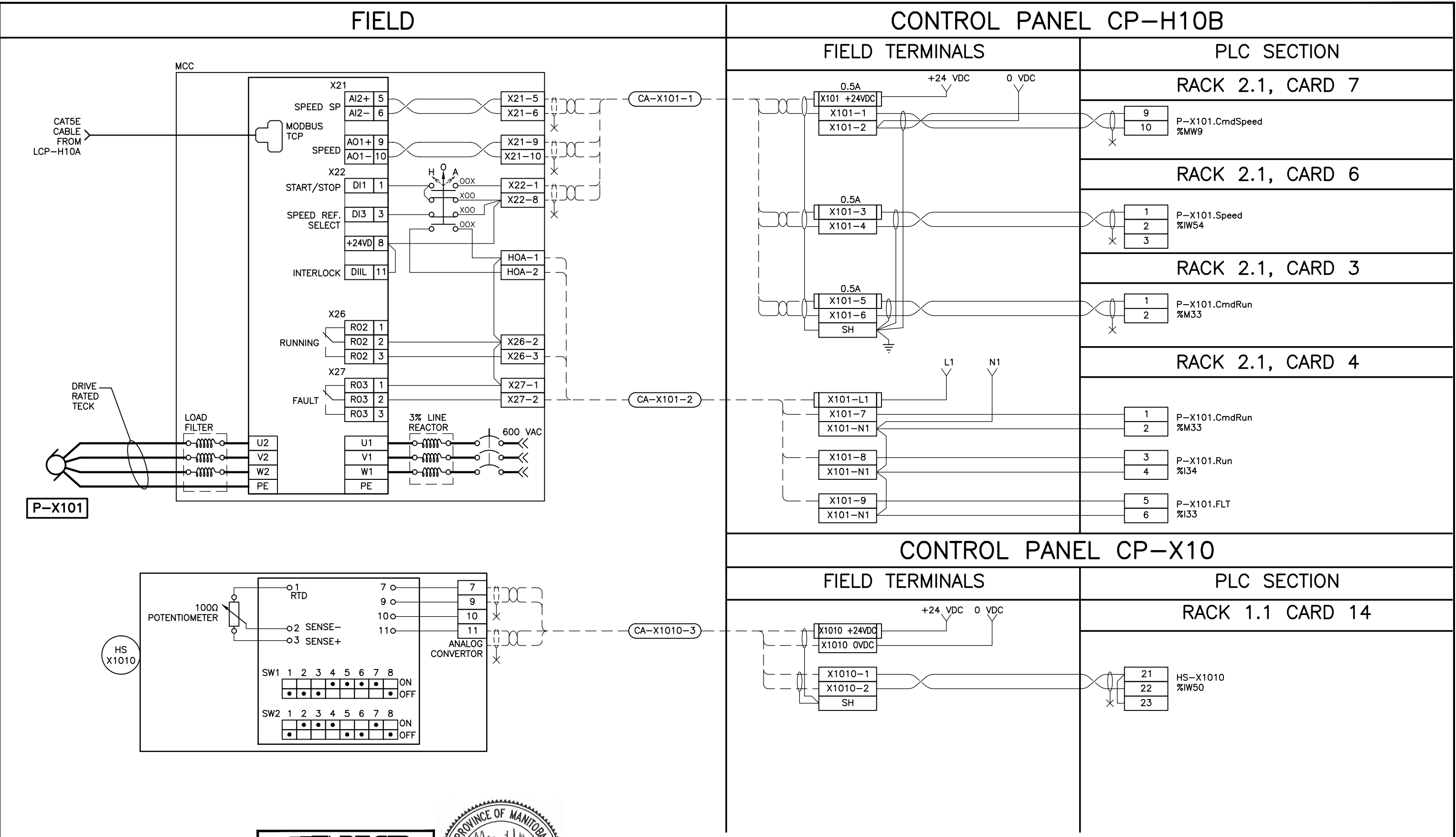

File Name: g:\cad\127079\contract\construction\loops\loop-dwg.dwg

APEGM
 Certificate of Authorization
 Dillon Consulting Limited (MB)
 No. 1789 Date: 2014-05-01

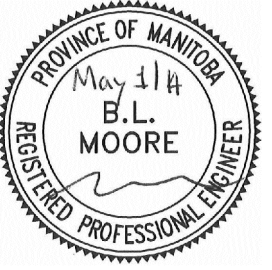

CH2MHILL.

DILLON CONSULTING
 DATE 2014-04-28

PROJECT CITY OF WINNIPEG WATER TREATMENT RESEARCH AND PROCESS OPTIMIZATION FACILITY
 TITLE INSTRUMENTATION P-X101 LOOP DIAGRAM

PROJECT NO. 127079
 FIGURE NO. 21

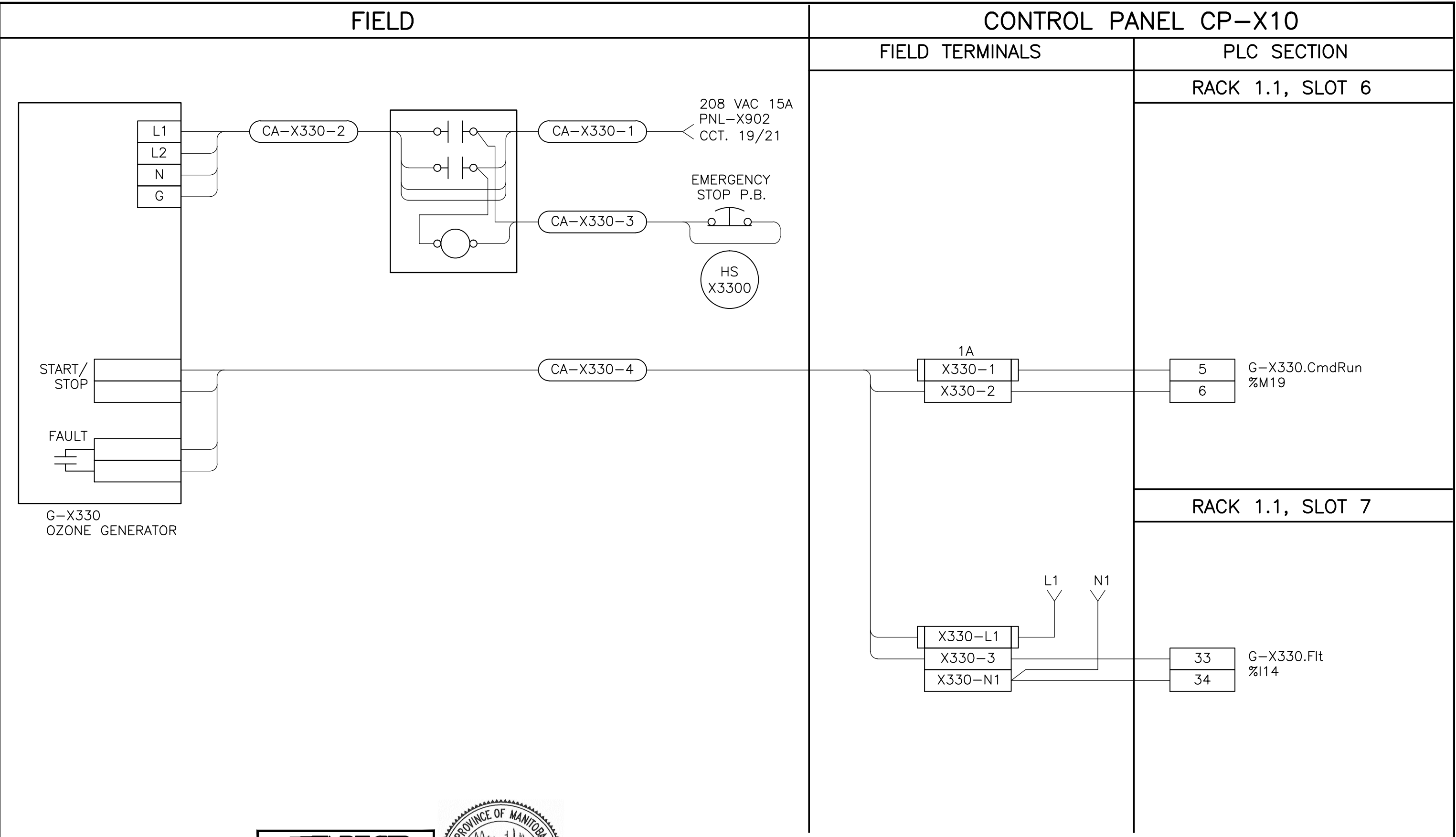

File Name: g:\cad\127079\contract\construction\loops loop-dwg.dwg

APEGM
 Certificate of Authorization
 Dillon Consulting Limited (MB)
 No. 1789 Date: 2014-05-01

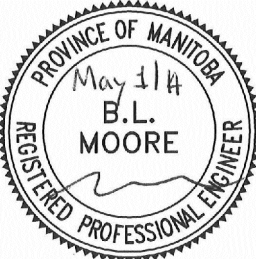

CH2MHILL.

DILLON CONSULTING
 DATE 2014-04-28

PROJECT	CITY OF WINNIPEG WATER TREATMENT RESEARCH AND PROCESS OPTIMIZATION FACILITY	PROJECT NO.	127079
TITLE	INSTRUMENTATION G-X330 LOOP DIAGRAM	FIGURE NO.	22

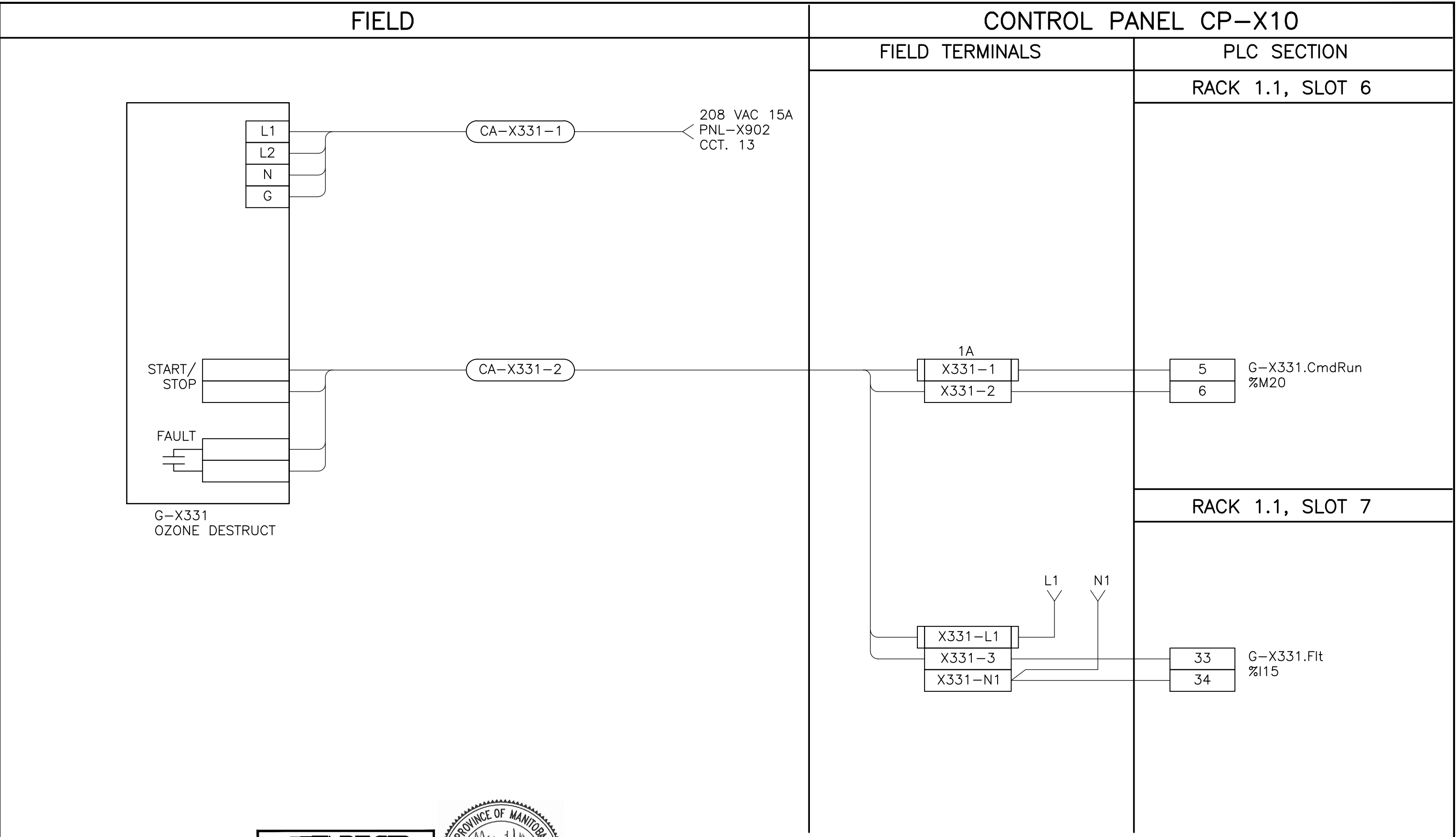

File Name: g:\cad\127079\contract\construction\loops loop-dwg.dwg

APEGM
 Certificate of Authorization
 Dillon Consulting Limited (MB)
 No. 1789 Date: 2014-05-01

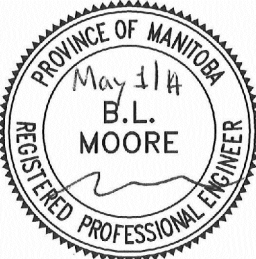

CH2MHILL.

DILLON CONSULTING
 DATE 2014-04-28

PROJECT	CITY OF WINNIPEG WATER TREATMENT RESEARCH AND PROCESS OPTIMIZATION FACILITY	PROJECT NO.	127079
TITLE	INSTRUMENTATION G-X331 LOOP DIAGRAM	FIGURE NO.	23

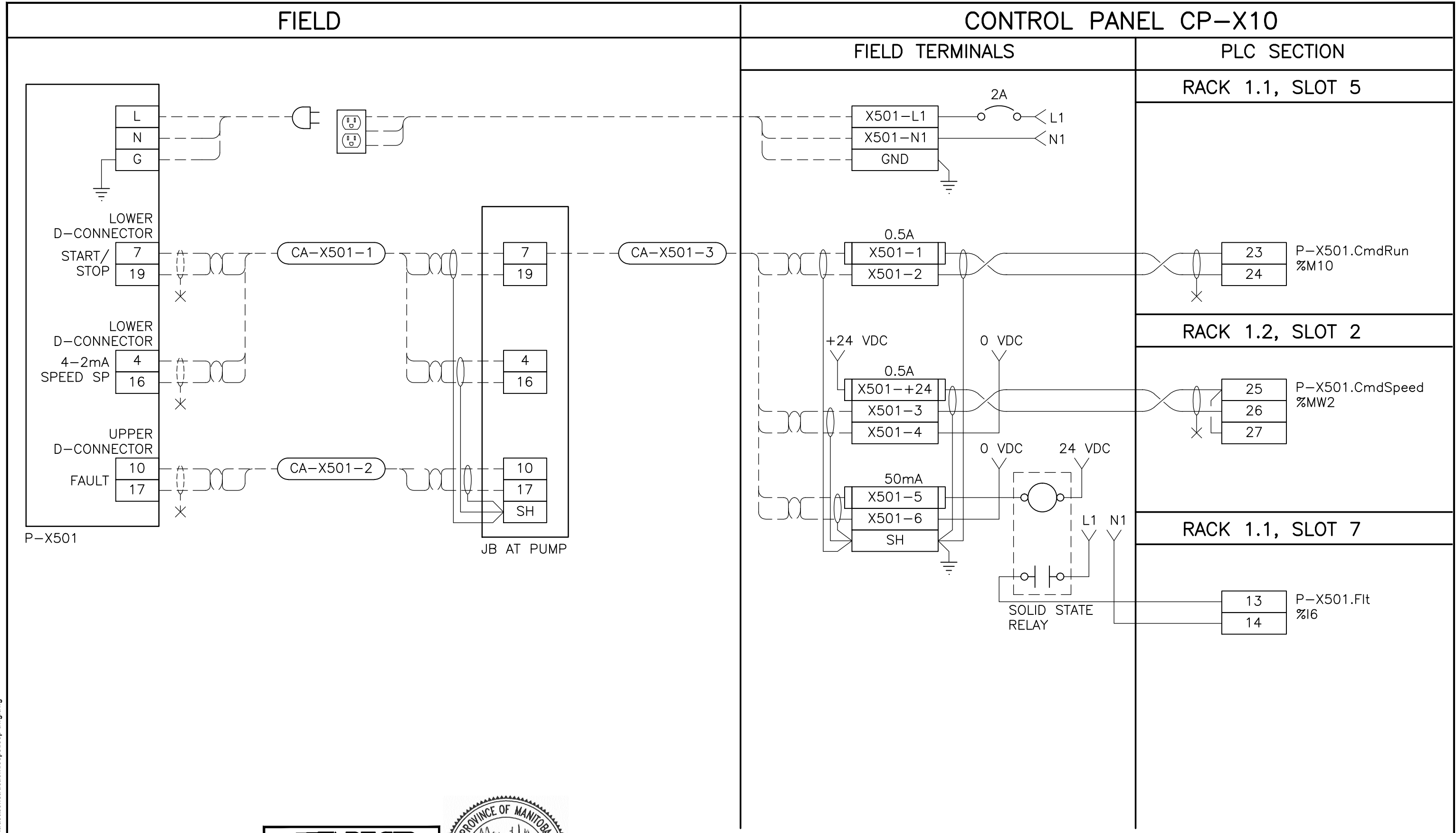

File Name: g:\cad\1127079\contract\construction\loops\loop-dwg.dwg

APEGM
 Certificate of Authorization
 Dillon Consulting Limited (MB)
 No. 1789 Date: 2014-05-01

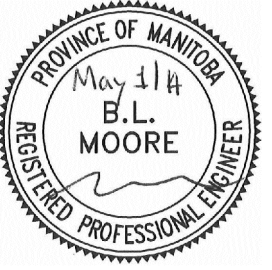

CH2MHILL.

DILLON CONSULTING
 DATE 2014-04-28

PROJECT CITY OF WINNIPEG WATER TREATMENT RESEARCH AND PROCESS OPTIMIZATION FACILITY
 TITLE INSTRUMENTATION P-X501 LOOP DIAGRAM

PROJECT NO. 127079
 FIGURE NO. 24

SECTION 29 40 51

PROGRAMMABLE LOGIC CONTROLLERS

PART 1 GENERAL

1.1 GENERAL REQUIREMENTS

- A. Install programmable logic controller (PLC)-based control panels for the WTRPO Facility at the Winnipeg WTP.
- B. The PLC control system includes a Ethernet Remote I/O network for remote I/O racks located in Electrical Room 1.
- C. Coordinate and cooperate with other contractors, suppliers, and the City's Representatives during system programming, start-up, and commissioning of the complete control system and associated field devices and wiring.
- D. PLC programming is provided by others.

PART 2 PRODUCTS

2.1 PROGRAMMABLE LOGIC CONTROLLERS

- A. General
 - 1. Floor standing enclosure.
 - 2. Cable entry via top.
 - 3. Terminate all field wiring on terminal blocks in PLC panels.
 - 4. Each PLC panel requires two (2) 120 VAC power supplies. One 15amp supply nearest 120 VAC panel board. One 15A supply from nearest UPS panel board.
 - 5. I/O signal voltage are based on the following:
 - a. Digital inputs and outputs: 120 VAC
 - b. Analog inputs and outputs: 4 to 20 mA, 24 VDC
 - c. RTD signal input

PART 3 EXECUTION

3.1 INSTALLATION

- A. Install the hardware in accordance with the foregoing requirements to satisfy the performance requirements defined in this and other Divisions of the Specification.
- B. Cooperate with other contractors, suppliers, the City and the Contract Administrator to commission and start-up the system as defined herein.

END OF SECTION

SECTION 29 50 01

INSTRUMENTATION SPECIFICATION SHEETS

PART 1 GENERAL

1.1 REFERENCES - GENERAL

- A. The Work includes the installation of all instrumentation which is detailed in instrument specification sheets.
- B. Refer to Section 29 05 00, Common Work Instrumentation.

1.2 INSTRUMENT SPECIFICATION SHEETS

- A. The data sheets included in this Section list specific minimum requirements for particular applications.

PART 2 PRODUCTS

2.1 SUPPLEMENTS

- A. The supplements listed below, following “End of Section” are part of this Specification.
 - 1. Refer to the following specification sheets:
 - a. I-101, Flow Meter
 - b. I-102, Paddle Wheel Flow Transmitter
 - c. I-103, Flow Rotameter
 - d. I-104, Temperature Indicator
 - e. I-105, Pressure Gauge
 - f. I-106, Pressure Gauge
 - g. I-107, Liquid Level Transmitter
 - h. I-108, Vibronic Level Switch
 - i. I-109, Turbidimeter
 - j. I-110, Particle Counter
 - k. I-111, Flow Through pH/Temperature Analyzer
 - l. I-112, Ambient Ozone Monitor
 - m. I-113, Flow Short-stroke Rotameter (Not Used)
 - n. I-114, Flow Rotameter
 - o. I-115, Solenoid Valve
 - p. I-116, Flow Through Dissolved Ozone Analyzer
 - q. I-117, Flow Switch
 - r. I-118, Solenoid Valve
 - s. I-119, Stack Light c/w Buzzer
 - t. I-120, Flow Rotameter c/w Flow Switch

PART 3 EXECUTION (Not Used)

END OF SECTION

INSTRUMENTATION SPECIFICATION SHEETS

INSTRUMENT SPECIFICATION NUMBER:	I-101
DEVICE:	Flow Meter
TAG:	Refer to Instrument Index, Section 29 40 21
TYPE:	Magnetic Flow Meter
SERVICE:	Water
SIZE AND MATERIAL:	NSF-61 approved
END CONNECTIONS:	Flanged
LINER MATERIAL:	Hard rubber
ELECTRODES:	Stainless Steel
GROUNDING:	Stainless Steel grounding rings
RANGE:	Refer to Instrument Index, Section 29 40 21
INACCURACY:	±0.2% for flows greater than 0.3 m per second
OUTPUT:	4 to 20 mADC into 500 ohm load; Scaled pulse output
POWER SUPPLY:	120 VAC, 60 Hz
INDICATION:	Local indication of flow rate and totalized flow
ELECTRONIC ENCLOSURE:	Flow tube IP67. Transmitter: NEMA 4X remote wall-mount.
MANUFACTURER AND MODEL:	Endress and Hauser, Promag53W

INSTRUMENTATION SPECIFICATION SHEETS

INSTRUMENT SPECIFICATION NUMBER: **I-102**

DEVICE: Paddle Wheel Flow Transmitter

TAG: Refer to Instrument Index, **Section 29 40 21**

SERVICE: Water

SIZE AND MATERIAL: Polypropylene, Titanium pin

RANGE: Refer to Instrument Index, **Section 29 40 21**

INACCURACY: $\pm 0.5\%$ of reading for 0.1 to 6 m/s

OUTPUT: 4 to 20 mADC into 500 ohm load

POWER SUPPLY: Loop Powered

INDICATION: Local indication of flow rate

ELECTRONIC ENCLOSURE: NEMA 4X.

MANUFACTURER AND MODEL: George Fischer Signet;
Transmitter: 3-8550-1
Flow Sensor: 3-8512-P0
Integral mount kit: 3-8051-1
Installation fitting: 310 PVC-U
Plastic tee

INSTRUMENTATION SPECIFICATION SHEETS

INSTRUMENT SPECIFICATION NUMBER: **I-103**

DEVICE: Flow Rotameter

TAG: Refer to Instrument Index, **Section 29 40 21**

SERVICE: Ozone, Compressed Air

SIZE AND MATERIAL:

Flange:	316L Stainless Steel
Housing:	304 Stainless Steel
Stoppers:	316L Stainless Steel
Measuring Cone:	Borosilicate glass
Float	Titanium
Gaskets:	EPDM

END CONNECTIONS: Flanged

MAX FLOW: 14 l/h

TURN DOWN: 20:1

INACCURACY: $\pm 1.6\%$ of reading

INDICATION: Local indication of flow rate

MANUFACTURER AND MODEL: Yokogawa: RAGN01-A1-SS-L6-23-TT-A-G-N;

INSTRUMENTATION SPECIFICATION SHEETS

INSTRUMENT SPECIFICATION NUMBER:	I-104
DEVICE:	Temperature Indicator
TAG:	Refer to Instrument Index, Section 29 40 21
SERVICE:	Ozone/Air mixture
SPAN:	0 to 100°C
SENSOR:	Bimetal Dial Thermometer
INACCURACY:	±1% of span
CONSTRUCTION:	Stainless steel wetted parts
MOUNTING:	Welded 316 Stainless Steel Thermowell
ACCESSORIES:	Stainless steel thermowell
MANUFACTURER AND MODEL:	Ashcroft: 20-CI-60-R-025-0/100°C

INSTRUMENTATION SPECIFICATION SHEETS

INSTRUMENT SPECIFICATION NUMBER:	I-105
DEVICE:	Pressure Gauge
TAG:	Refer to Instrument Index, Section 29 40 21
SERVICE:	Water
PROCESS CONNECTION:	1/4 inch NPT
SENSOR:	316L Stainless Steel
RANGE:	Refer to Instrument Index, Section 29 40 21
MOUNTING:	Bottom, Stem mounted
ENCLOSURE:	IP54
MANUFACTURER AND MODEL:	Ashcroft: 45-1259-SD-02L-1000kpa

INSTRUMENTATION SPECIFICATION SHEETS

INSTRUMENT SPECIFICATION NUMBER: I-106

DEVICE: Pressure Gauge

TAG: Refer to Instrument Index, **Section 29 40 21**

SERVICE: Ozone/Air mixture

PROCESS CONNECTION: 1/4 inch NPT

SENSOR: 316L Stainless Steel

RANGE: Refer to Instrument Index, **Section 29 40 21**

MOUNTING: Bottom, Stem mounted

ENCLOSURE: IP54

MANUFACTURER AND MODEL: Ashcroft: 45-1259-SD-02L-400kpa

INSTRUMENTATION SPECIFICATION SHEETS

INSTRUMENT SPECIFICATION NUMBER:	I-107
DEVICE:	Liquid Level Transmitter
TAG:	Refer to Instrument Index, Section 29 40 21
TYPE:	Ultrasonic
SERVICE:	Refer to Instrument Index and P&ID Diagrams
RANGE:	Refer to Instrument Index, Section 29 40 21
INACCURACY:	±0.5% of span
OUTPUT:	4 to 20 mA DC into 500 ohm load 5 configurable alarm relays
POWER SUPPLY:	Loop Powered
ENCLOSURE:	NEMA 4X Transmitter/Sensor Housing
MOUNTING:	Provide 100 mm PVC pipe stilling well where shown on the drawings and in accordance with manufacturer's recommendations to ensure stable readings in turbulent locations. Mount sensor on stilling well. Stilling well shall extend 300 mm above top of tank. Drill 3 25mm holes at top of tank. Install sensors at least 300 mm above maximum liquid level. Provide PVC blind flange for mounting sensor.
MANUFACTURER AND MODEL:	Endress & Hauser: FMU40-N-N-B-2-A-4-1

INSTRUMENTATION SPECIFICATION SHEETS

INSTRUMENT SPECIFICATION NUMBER:	I-108
DEVICE:	Vibronic Level Switch
TAG:	Refer to Instrument Index, Section 29 40 21
SERVICE:	Refer to Instrument Index and P&ID Diagrams
RANGE:	13 mm
OUTPUT:	250 mA, 24 VDC
CONNECTOR:	M12x1
POWER SUPPLY:	24 VDC
ENCLOSURE:	IP66/67
MOUNTING:	Mount vertically 0.1 mm AFF
MANUFACTURER AND MODEL:	Endress & Hauser: Liquiphant T FTL20-3-2-2-D

INSTRUMENTATION SPECIFICATION SHEETS

INSTRUMENT SPECIFICATION NUMBER:	I-109
DEVICE:	Turbidimeter
TAG:	Refer to Instrument Index, Section 29 40 21
SERVICE:	Refer to Instrument Index and P&ID Diagrams
MOUNTING:	Wall mount.
RANGE:	0.001 – 100 NTU
INACCURACY:	±2% of reading from 0 to 40 NTU; ±5% of reading from 40 to 100 NTU
REPEATABILITY	Less than 1% of reading
OUTPUT:	4 to 20 ma DC into 500 ohm load 2 Configurable alarm relays including a dedicated fault relay
POWER SUPPLY:	120 VAC, 60 Hz
INDICATION:	Local indication of Turbidity
ELECTRONIC ENCLOSURE:	NEMA 4X.
LIGHT SOURCE:	Infrared LED, 860 nm.
MANUFACTURER AND MODEL:	Endress & Hauser: TURBIMAX CUE21 complete with flow chamber

INSTRUMENTATION SPECIFICATION SHEETS

INSTRUMENT SPECIFICATION NUMBER:	I-110
DEVICE:	Particle Counter
TAG:	Refer to Instrument Index, Section 29 40 21
SERVICE:	Filtered Water
MOUNTING:	Wall mount.
RANGE:	0-2500 particles
PARTICLE SIZE:	2-50 micron threshold
OUTPUT:	Four (4) - 4 to 20 ma DC into 500 ohm loads Dedicated fault relay
POWER SUPPLY:	120 VAC, 60 Hz
INDICATION:	Local indication of Particle Count
ENCLOSURE:	NEMA 4X.
MANUFACTURER AND MODEL:	Hach 2200 PCX

INSTRUMENTATION SPECIFICATION SHEETS

INSTRUMENT SPECIFICATION NUMBER:	I-111
DEVICE:	Flow Through pH/Temperature Analyzer
TAG:	Refer to Instrument Index, Section 29 40 21
SERVICE:	Refer to Instrument Index and P&ID Diagrams
SENSOR MATERIAL:	Glass electrode
SENSOR MOUNTING	Wall mount
TEMPERATURE COMPENSATION:	Automatic, 0 to 100°C
RANGE:	0-14 pH
INACCURACY:	Less than $\pm 0.5\%$ of span
REPEATABILITY	Less than 0.01 pH
OUTPUT:	Two 4-20 mA DC outputs for process measurement and temperature 1 Configurable alarm relay
POWER SUPPLY:	120 VAC, 60 Hz
INDICATION:	Local indication of pH and temperature
ENCLOSURE:	NEMA 4X transmitter housing. Wall-mount sensor and transmitter.
ACCESSORIES:	Flow body with needle valve and flow switch
MANUFACTURER AND MODEL:	Endress & Hauser: CPS11-2-BA-2-ESA c/w CCA250-M-0 and Liquisys M CPM253 transmitter

INSTRUMENTATION SPECIFICATION SHEETS

INSTRUMENT SPECIFICATION NUMBER:	I-112
DEVICE:	Ambient Ozone Monitor
TAG:	Refer to Instrument Index, Section 29 40 21
SERVICE:	Refer to Instrument Index and P&ID Diagrams
MEASURING PRINCIPLE:	UV absorption with automatic zeroing
MOUNTING	Wall mount
RANGE:	0-1, 0-10, 0-10,000 ppm
INACCURACY:	Less than $\pm 0.5\%$ of span
REPEATABILITY	Less than 0.01 pH
OUTPUT:	4-20 mA DC outputs for process measurement 2 Configurable alarm relay
POWER SUPPLY:	120 VAC, 60 Hz
INDICATION:	Local indication of pH and temperature
ENCLOSURE:	NEMA 4X wall mount.
MANUFACTURER AND MODEL:	IN UAS Inc: IN-2000-L2-LC

INSTRUMENTATION SPECIFICATION SHEETS

INSTRUMENT SPECIFICATION NUMBER:	I-113 (Not Used)
DEVICE:	Flow Short-stroke Rotameter
TAG:	Refer to Instrument Index, Section 29 40 21
SERVICE:	Water
SIZE AND MATERIAL:	Flange: 316L Stainless Steel Housing: 304 Stainless Steel Stoppers: 316L Stainless Steel Gaskets: EPDM
END CONNECTIONS:	Flanged
MAX FLOW:	130 m ³ /h
INACCURACY:	±1.6% of reading
INDICATION:	Local indication of flow rate
MANUFACTURER AND MODEL:	Yokogawa: RAMC15-A1-SS-nnn-T-90-NNN

INSTRUMENTATION SPECIFICATION SHEETS

INSTRUMENT SPECIFICATION NUMBER: I-114

DEVICE: Flow Rotameter

TAG: Refer to Instrument Index, **Section 29 40 21**

SERVICE: Compressed Air

SIZE AND MATERIAL:

Flange:	316L Stainless Steel
Housing:	304 Stainless Steel
Stoppers:	316L Stainless Steel
Measuring Cone:	Borosilicate glass
Float	Titanium
Gaskets:	EPDM

END CONNECTIONS: Flanged

MAX FLOW: As indicated

MAX PRESSURE: 16 BAR

TURN DOWN: 20:1

INACCURACY: $\pm 1.6\%$ of reading

INDICATION: Local indication of flow rate

MANUFACTURER AND MODEL: Yokogawa: RAGN01-A1-SS

INSTRUMENTATION SPECIFICATION SHEETS

INSTRUMENT SPECIFICATION NUMBER: I-115

DEVICE: Solenoid Valve

TAG: Refer to Instrument Index, **Section 29 40 21**

SERVICE: Compressed Air

SIZE AND MATERIAL:

Body:	Brass
Seals and Discs:	PTFE
Disc-holder:	PA
Core Tube:	305 SS
Core and Plugnut	430F SS
Springs:	302 SS
Shading Coil:	Copper

END CONNECTIONS: NPT

MAX PRESSURE: 1500 kPa

COIL VOLTAGE: 120 VAC

MANUFACTURER AND MODEL: ASCO, 8210 Series, 8210G007, complete with junction box.

INSTRUMENTATION SPECIFICATION SHEETS

INSTRUMENT SPECIFICATION NUMBER:	I-116
DEVICE:	Flow Through Dissolved Ozone Analyzer
TAG:	Refer to Instrument Index, Section 29 40 21
SERVICE:	Refer to Instrument Index and P&ID Diagrams
SENSOR:	Membrane covered ampere-metric
SENSOR MOUNTING	Wall mount
TEMPERATURE COMPENSATION:	Automatic, 0 to 100°C
RANGE:	0-3 ppm
INACCURACY:	Less than $\pm 0.5\%$ of span
REPEATABILITY	+/- 2% of reading at constant temperature
OUTPUT:	Two 4-20 mA DC outputs for process measurement and temperature 1 Configurable alarm relay
POWER SUPPLY:	120 VAC, 60 Hz
INDICATION:	Local indication of dissolved ozone and temperature
ENCLOSURE:	NEMA 4X transmitter housing. Wall-mount sensor and transmitter.
ACCESSORIES:	Flow body with needle valve
MANUFACTURER AND MODEL:	Rosemount 1056-03-26-38-AN complete with 499AOZ sensor

INSTRUMENTATION SPECIFICATION SHEETS

INSTRUMENT SPECIFICATION NUMBER:	I-117
DEVICE:	Flow Switch (Thermal Dispersion)
TAG:	Refer to Instrument Index, Section 29 40 21
SERVICE:	Potable water
PROCESS CONNECTION:	1/4 inch NPT
SENSOR:	316 Stainless Steel, mini sensor (twin tip)
OUTPUT:	8 amp DPDT relay
POWER SUPPLY:	24 VDC
MOUNTING:	25 mm Tee
ENCLOSURE:	NEMA 4
MANUFACTURER AND MODEL:	Magnetrol: TEM-A210-001

INSTRUMENTATION SPECIFICATION SHEETS

INSTRUMENT SPECIFICATION NUMBER: **I-118**

DEVICE: Solenoid Valve

TAG: Refer to Instrument Index, **Section 29 40 21**

SERVICE: Filter Effluent Sampling

SIZE AND MATERIAL:

Body:	CPVC
Gasket Material:	Viton
O-rings:	FPM
Coil:	Corrosion-resistant polyester

END CONNECTIONS: 1" Socket/Threaded

TYPE: Direct Acting

MAX PRESSURE: 827 kPa

COIL VOLTAGE: 120 VAC

MANUFACTURER AND MODEL: Hayward, SV20100STV

INSTRUMENTATION SPECIFICATION SHEETS

INSTRUMENT SPECIFICATION NUMBER: **I-119**

DEVICE: Stack Light complete with Audible Buzzer

TAG: Refer to Instrument Index, **Section 29 40 21**

SERVICE: Ambient Ozone Alarm Signalling

BASE UNIT: Black c/w cover
70mm

VISUAL SIGNALLING UNITS: Red and Orange
LED
70mm, IP65
120VAC

AUDIBLE SIGNALLING UNIT: Adjustable Buzzer
70 mm
120 VAC

MOUNTING: Fixing Base: Black Plastic
Support Tube: Aluminum, 780mm

MANUFACTURER AND MODEL: Schneider Harmony, 70mm modular tower lights
Base: XVBC21
Red Light: XVBC2G4
Orange Light: XVBC2G5
Audible Buzzer: XVBC9M
Mount: XVBZ04A

INSTRUMENTATION SPECIFICATION SHEETS

INSTRUMENT SPECIFICATION NUMBER:	I-120
DEVICE:	Flow Rotameter
TAG:	Refer to Instrument Index, Section 29 40 21
SERVICE:	Refer to Instrument Index, Section 29 40 21
SIZE AND MATERIAL:	Materials selected based on chemical compatibility as provided in the Instrument Index, Section 29 40 21
MAX RANGE:	As indicated
MAX PRESSURE:	16 BAR
TURN DOWN:	20:1
INACCURACY:	±1.6% of reading
INDICATION:	Local indication of flow rate
OUTPUT:	Contact Output Based On Flow, 120V rated
MANUFACTURER AND MODEL:	Yokogawa: RAG